

Integrated High Speed Dome Camera



Outdoor

User's Manual

Version 3.2

Preface

The information given in this manual was current when published. The company reserves the right to revise and improve its products. All specifications are subject to change without notice.

Notice

To work with the Integrated High Speed Dome Cameras, any installer or technician must have the following minimum qualifications:

- A basic knowledge of CCTV systems and components
- A basic knowledge of electrical wiring and low-voltage electrical hookups
- A basic knowledge of network system setting
- Have read this manual completely

Copyright



Under copyright laws, the contents of this user manual may not be copied, photocopied, translated, reproduced or reduced to any electronic medium or machine-readable format, in whole or in part, without prior written permission of the company.

Important Information

Before proceeding, please read and observe all instructions and warnings in this manual. Retain this manual with the original bill of sale for future reference and, if necessary, warranty service. When unpacking your unit, check for missing or damaged items. If any item is missing, or if damage is evident, **DO NOT INSTALL OR OPERATE THIS PRODUCT**. Contact your dealer for assistance.

Regulation

| | |
|---|--|
|  | This device complies with Part 15 of the FCC Rules. Operation is subject to the following two conditions: (1) this device may not cause harmful interference, and (2) this device must accept any interference received, including interference that may cause undesired operation. |
|---|--|

| | |
|--|---|
|  | <p>This symbol on the product or on its packaging indicates that this product shall not be treated as household waste in accordance with Directive 2002/96/EC. Instead it shall be handed over to the applicable collection point for the recycling of electrical and electronic equipment. By proper waste handling of this product you ensure that it has no negative consequences for the environment and human health, which could otherwise be caused if this product is thrown into the garbage bin. The recycling of materials will help to conserve natural resources.</p> <p>For more details information about recycling of this product, please contact your local city office, your household waste disposal service or the shop where you purchased the product.</p> |
|  | <p>Compliance is evidenced by written declaration from our suppliers, assuring that any potential trace contamination levels of restricted substances are below the maximum level set by EU Directive 2002/95/EC, or are exempted due to their application.</p> |

Cautions

- **Handle the camera carefully**
Do not abuse the camera. Avoid striking, shaking, etc. The camera could be damaged by improper handling or storage.
- **Installing electricity wiring carefully**
Ask qualified personnel of electrical wiring for the installation. Please note that input electricity to the unit is at tolerance of DC 12V/AC 24V \pm 10%.

The camera is capable of surge protection; ensure AC power model unit grounded appropriately against damage of heavy current or electric shock. Refer to the camera's installation guide for more information.

- **Do not disassemble the camera**
To prevent electric shock, do not remove screws or covers. There are no user serviceable parts inside. Ask a qualified service person for servicing.
- **Do not block cooling holes on the bracket**
This camera has a cooling fan inside. Blocking the cooling holes leads to build up of heat the camera and may cause malfunction.
- **Do not operate the camera beyond the specified temperature, humidity or power source ratings**
Use the camera under conditions where temperature is between 45°C ~ 50°C (-49°F ~ 122°F), and humidity is below 90%.
- **Do not expose the camera to rain or moisture, or try to operated it in wet areas**
This product is designed for indoor use or locations where it is protected from rain and moisture. Turn the power off immediately if the camera is wet and ask a qualified service person for servicing. Moisture can damage the camera and also create the danger of electric shock.
- **Do not use strong or abrasive detergents when cleaning the camera body**
Use a dry cloth to clean the camera when dirty. In case the dirt is hard to remove, use a mild detergent and wipe gently.

- **Never face the camera towards the sun**

Do not aim the camera at bright objects. Whether the camera is in use or not, never aim it at the sun or other extremely bright objects. Otherwise, the camera may be smeared or damaged.

Table of Contents

| | |
|---|-----------|
| 1. Overview..... | 7 |
| 1.1 Product Features..... | 8 |
| 1.2 Product Application | 9 |
| 2. Connecting the High Speed Dome..... | 10 |
| 2.1 Package Contents | 10 |
| 2.2 Switch/Connector Definition | 12 |
| 2.3 Communication Switch Setting..... | 13 |
| 2.3.1 Analog Dome Camera | 13 |
| 2.3.2 IP Dome Camera..... | 14 |
| 2.4 ID Setting..... | 14 |
| 2.4.1 Analog Dome Camera | 14 |
| 2.4.2 IP Dome Camera..... | 15 |
| 2.5 Camera Control Protocol Setting..... | 15 |
| 2.5.1 Analog Dome Camera | 16 |
| 2.5.2 IP Dome Camera..... | 17 |
| 2.6 22-Pin Connector Definition | 17 |
| 2.6.1 Analog Dome Camera | 17 |
| 2.6.2 IP Dome Camera..... | 19 |
| 2.7 RS-485 Connector Definition (Analog)..... | 20 |
| 3 Operation and Configuration..... | 21 |
| 3.1 Display Format | 21 |
| 3.2 OSD Menu Tree | 22 |
| 3.2.1 G/V/T Model | 22 |
| 3.2.2 L/M/R Model | 25 |
| 3.2.3 S1/S2 Model | 28 |
| 3.3 Configuration Menu | 31 |
| 3.3.1 LANGUAGE..... | 32 |
| 3.3.2 DEFAULT CAMERA..... | 32 |
| 3.3.3 BACKLIGHT | 32 |
| 3.3.4 FOCUS | 34 |
| 3.3.5 AE MODE | 37 |
| 3.3.6 WBC MODE | 41 |
| 3.3.7 SETUP MENU 1 | 43 |
| ZOOM SPEED..... | 43 |
| DIGITAL ZOOM..... | 44 |
| SLOW SHUTTER | 44 |
| DIGITAL NOISE REDUCTION (S1/S2 Model) | 45 |
| IMAGE INVERSE (Excluding R Model)..... | 45 |
| FREEZE (Excluding R Model) | 46 |

| | | |
|--------|---|-----------|
| | APERTURE | 46 |
| | STABILIZER (L Model)..... | 46 |
| | EXIT..... | 47 |
| 3.3.8 | SETUP MENU 2 | 47 |
| | FLIP | 47 |
| | ANGLE ADJUSTER | 48 |
| | SPEED BY ZOOM..... | 48 |
| | AUTO CALI. (Auto Calibration)..... | 48 |
| | PASSWORD (S1/S2 Model)..... | 49 |
| | OSD AUTO CLOSE (S1/S2 Model)..... | 49 |
| | SYSTEM RESET | 50 |
| | EXIT..... | 50 |
| 3.3.9 | ID DISPLAY | 51 |
| 3.3.10 | TITLE DISPLAY..... | 51 |
| 3.3.11 | TITLE SETTING | 51 |
| 3.3.12 | PRESET | 53 |
| 3.3.13 | SEQUENCE | 54 |
| 3.3.14 | AUTOPAN | 56 |
| 3.3.15 | CRUISE | 58 |
| 3.3.16 | HOME SETTING | 59 |
| 3.3.17 | IR FUNCTION (Removable IR Cut Filter)..... | 61 |
| 3.3.18 | ALARM SETTING..... | 64 |
| 3.3.19 | LARM DETECT (G/V/T/L/M Model)..... | 67 |
| 3.3.20 | WDR FUNCTION (G/V/T/L/M Model)..... | 71 |
| 3.3.21 | PRIVACY MASK (Excluding R Model) | 72 |
| 3.3.22 | TIME SETTING | 77 |
| 3.3.23 | SCHEDULE | 78 |
| 3.3.24 | EXIT OSD..... | 79 |
| | Appendix A: Technical Specification..... | 80 |
| | OSD Menu Notes..... | 84 |
| | <G/V/T Model> | 84 |
| | <L/M/R Model> | 87 |
| | <S1/S2 Model> | 90 |

1. Overview

The Dome Camera delivers up to 432x zoom ratio (T model) to capture clear image in the distance. Continuous Auto Focus, Back Light Compensation, Auto Exposure and Digital Slow Shutter functions are provided for clear and high quality image. Removable IR cut filter ensures 24 hours operation, while Privacy Masks are specially designed to avoid any intrusive monitoring at specific region; all of the salient functions can be incorporated to meet your needs. The Home function allows users to specify a preset position as the 'home position' or home functions (Sequence/Auto-pan/Cruise). Under the mode, Dome Cameras can come back to the preset home position or functions when the camera has been idle for a user-defined period of time. Additionally, the unique Schedule function enables users to program a preset point or function (Sequence/Auto-pan/Cruise) so that these actions can be automatically performed in certain period of time.

The Dome Camera provides variable pan/tilt speeds ranging from a fast patrol of 400° per second to a slow ramble of 5° per second with 0.225° pan/tilt accuracy for fast and accurate tracking ability. The 360° endless rotation and -10°~190° tilt travel make tracking the object passing directly beneath the dome. Maximum 256 preset points can be programmed for precise location of target areas, and users can also define Sequence lines, Auto-Pan lines and Cruise routes for the camera to operate automatically. In addition, RS-485 communication port is available for remote control purposes.

The Integrated High Speed Dome Camera provides 8 alarm inputs and 1 alarm relay output, and the smart alarm management mechanism can be programmed through the OSD setup menu; certain function (Preset/Sequence/Auto-Pan/Cruise) can be activated when an alarm is triggered.

Large set of built-in protocols provide connectivity to other surveillance systems. The built-in protocols include DynaColor, Pelco, VCL, Philips, AD-422, etc, which allow the Dome Camera series to be integrated with other suppliers' surveillance systems.

1.1 Product Features

Precise and Accurate Performance

- Auto Calibration
- Preset accuracy of 0.225°
- Preset speed up to 400°/sec.
- Proportional Pan & Tilt Speed
- Preset Position/Sequence /Auto-Pan /Cruise

Dynamic Applications

- Multi-language OSD
- Schedule function
- Multiple built-in Protocols
- Up to 24 masking zones (Optional)
- 8 alarm inputs, 1 alarm output
- Motion Detection (Optional)
- Flexible mountings
- Compact lightweight design for easy installation
- Weather resistant housing
- All-in-one type

Superior Camera Image Quality

- Minimum illumination 0.01 Lux (B/W)
- Digital Slow Shutter
- Electronic Shutter
- Wide Dynamic Range (Optional)
- Auto White Balance
- Backlight Compensation
- Auto Exposure
- Image Inverse (Optional)
- Electronic Image Stabilizer (Optional)
- Removable IR Cut Filter (Optional)

1.2 Product Application

Connect the Dome Camera to other devices as shown in the diagram to complete a video surveillance solution.

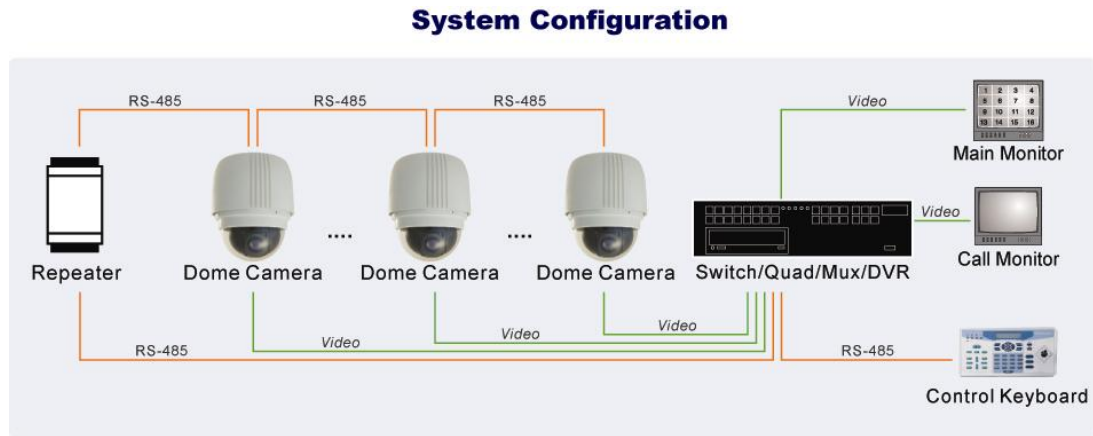

NOTE: To extend the network distance up to 1.2 km (4000 feet) and to protect the connected devices, it is highly recommended to place a repeater at the mid-point. However, a repeater may be needed in the network distance less than 1.2 km if the used cables are not the CAT 5, 24-gauge cables; see [2.7 RS-485 Connector Definition](#). Refer to the repeater's manual for detailed information.

2. Connecting the High Speed Dome

Please refer to the following sections to connect, set and operate the Dome Camera. In order to control the Integrated High Speed Dome Camera, basically a control keyboard or other control device is required.

2.1 Package Contents

Before proceeding, please check the box contains the items listed here. If any item is missing or has defects, DO NOT install or operate the product and contact your dealer for assistance.

Analog Dome Camera Package

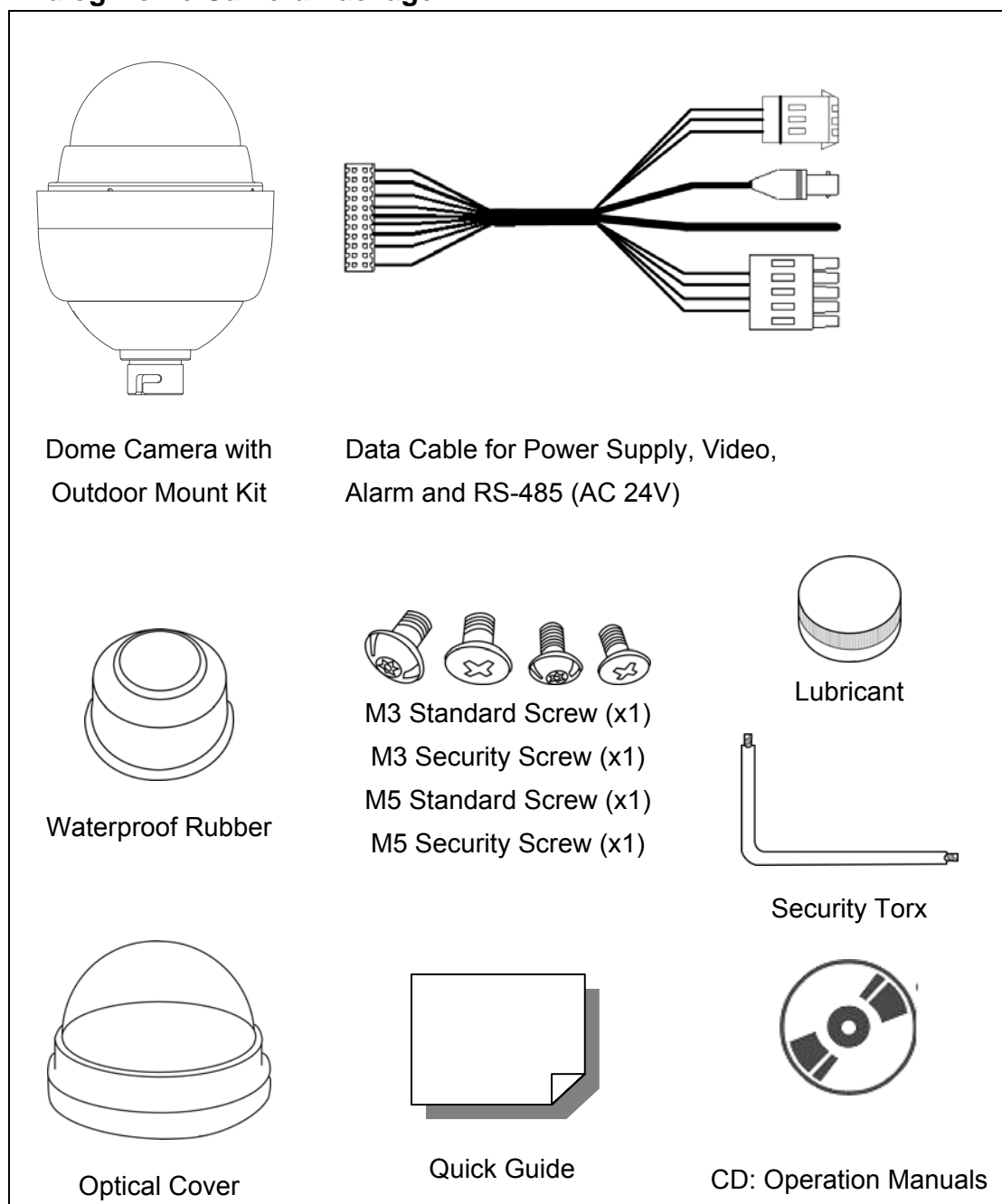

IP Dome Camera Package

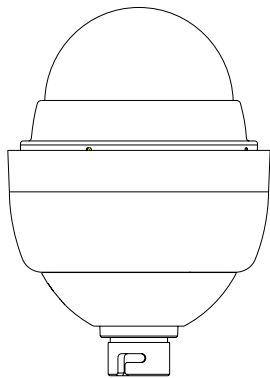

Dome Camera with Outdoor Mount Kit

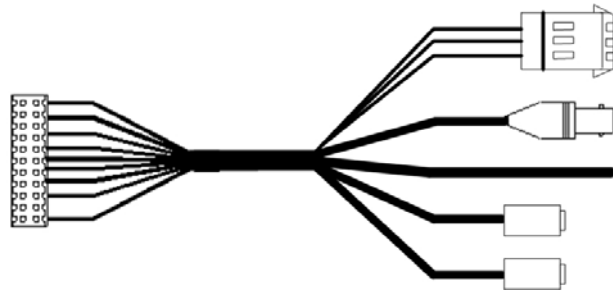

Data Cable for Power Supply, Video, Audio and Alarm (AC 24V)

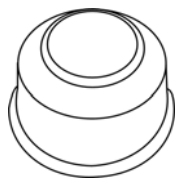

Waterproof Rubber

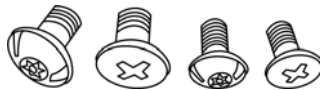

M3 Standard Screw (x1)
M3 Security Screw (x1)
M5 Standard Screw (x1)
M5 Security Screw (x1)

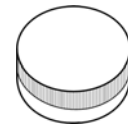

Lubricant



Security Torx

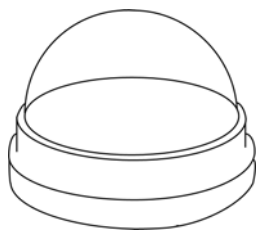

Optical Cover

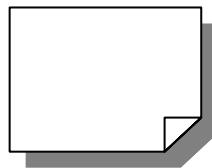

Quick Guide



CD: Operation Manuals

2.2 Switch/Connector Definition

Configuring the Dome Camera's ID and communication protocol are required before connecting the analog camera to other devices. The switches used for configuring these settings are located on the bottom of the Dome Camera. Additionally, the 22-Pin Connector for Data Cable connection and ISP Connector for firmware upgrade kit connection are located on the back plate of both analog and IP Dome Cameras.

Please refer to the diagrams and tables of switch/connector definition below.

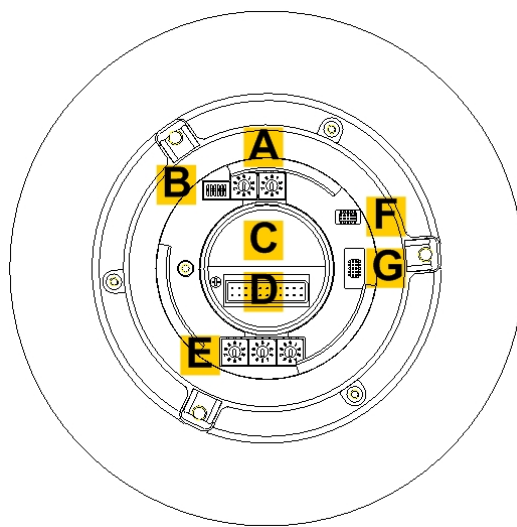

Analog

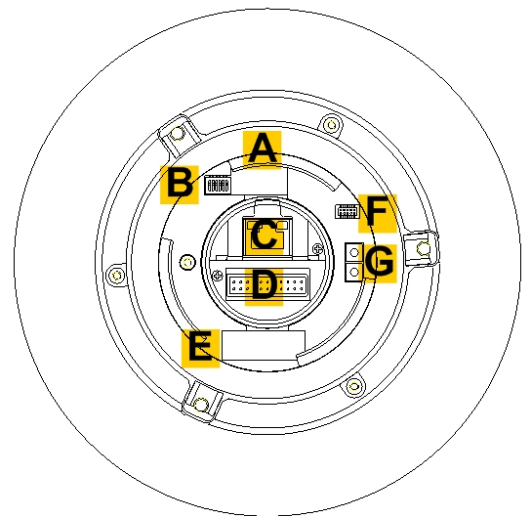

IP

| | |
|----------|--------------------------------|
| A | Camera Control Protocol Switch |
| B | Communication Switch |
| C | None |
| D | 22-Pin Connector |
| E | ID Switch |
| F | Reserved |
| G | ISP Connector (for FW upgrade) |

| | |
|----------|--------------------------------|
| A | None |
| B | Communication Switch |
| C | RJ-45 Connector |
| D | 22-Pin Connector |
| E | None |
| F | Reset Buttons |
| G | ISP Connector (for FW upgrade) |

2.3 Communication Switch Setting



The next two sections provide information about communication switch setting for the analog and IP Dome Cameras.

2.3.1 Analog Dome Camera

The analog Dome Camera's communication switches are specified in the table below.

| Communication Switch | | SW 1 | RS-485 Setting |
|---|------|-----------------------|----------------|
|  | SW 2 | | |
| | SW 3 | Termination | |
| | SW 4 | Line Lock | |
| | SW 5 | System Initialization | |
| | SW 6 | Reserved | |

RS-485 is the interface that communicates the Dome Camera and its control device; for this reason, the RS-485 setup of the Dome Camera and the control device must be the same. The RS-485 default setting is half-duplex (see the diagram follows). Please do not change the default setting without qualified specialist or supplier's notice. As for the SW 3 and SW 4, they are used for termination and Line Lock adjustment respectively. The SW 5 is mainly used when users want to set the camera to the factory default status; moreover, once firmware upgrade is carried out, users also need to adjust the SW 5 afterward.

| RS-485 Setting | |
|--|--|
| <p>Half-duplex</p>  | <p>Full-duplex</p>  |

2.3.2 IP Dome Camera

The IP Dome Camera's communication switches are specified in the table below. Each switch's default setting is shown as the figure below. DO NOT change the default setting, or some functions may not work properly.

| Communication Switch | SW 1 | SW 2 | SW 3 | SW 4 | SW 5 | SW 6 |
|---|------|------|------|------|------|-----------------------|
|  | | | | | | |
| | | | | | | Audio Setting |
| | | | | | | Termination |
| | | | | | | Line Lock |
| | | | | | | System Initialization |
| | | | | | | Reserved |

Turn on the SW 5 can restore the camera to the factory default status; moreover, once firmware upgrade is carried out, users also need to reset the SW 5 afterward.

2.4 ID Setting

The way to set the analog and IP Dome Cameras' ID number is specified as follows.

2.4.1 Analog Dome Camera

Please change the analog Dome Camera's ID if there is more than one Dome Camera on the same installation site. Use the switch to change your Speed Dome Camera's ID by turning the arrow to the desired number respectively. For instance, if the camera's ID is 123, the ID switch should be set as below.



NOTE: No two Dome Cameras should be given the same ID, or communication conflict may occur.

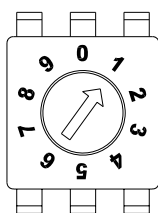

Centesimal Digit

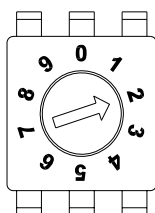

Decimal Digit

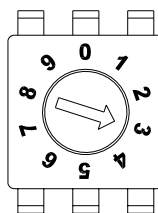

Single Digit



NOTE: The number “0” should locate upwards as shown in above diagram for correct switch definition.

2.4.2 IP Dome Camera

Set the Dome Camera’s ID to “001” as shown below. Please set every IP Dome Camera’s ID to “001” even you install multiple IP Dome Cameras.

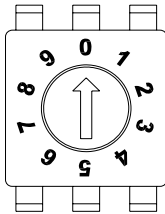

Centesimal Digit

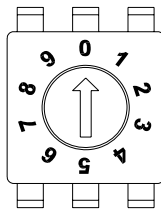

Decimal Digit

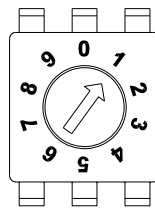

Single Digit

2.5 Camera Control Protocol Setting

Define the protocol you are going to use basing on the devices of your surveillance system. Generally, use one protocol even the devices are provided from different manufacturers. Please refer to the table below for all supported protocols with their matching switch numbers and baud rate and choose a protocol for your Speed Dome Camera.

2.5.1 Analog Dome Camera

The table below shows various protocols with their matching switch numbers and baud rate.

| Switch No. | Protocol | Baud Rate |
|------------|-------------|-----------|
| 00 | VCL | 9600 |
| 01 | Pelco D | 2400 |
| 02 | Pelco P | 4800 |
| 04 | Chiper | 9600 |
| 05 | Philips | 9600 |
| 07 | DSCP | 9600 |
| 08 | AD422 | 4800 |
| 09 | DM P | 9600 |
| 11 | Pelco D | 4800 |
| 12 | Pelco D | 9600 |
| 13 | Pelco P | 2400 |
| 14 | Pelco P | 9600 |
| 15 | JVC | 9600 |
| 21 | Kalatel-485 | 9600 |
| 22 | Kalatel-422 | 4800 |

Select protocol: Pelco D, with switch no. 01 and baud rate 2400, for instance, the protocol switch should be set as below.

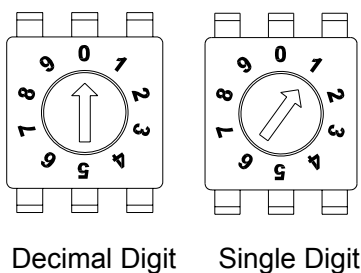

NOTE: The number "0" should locate upwards as shown in above diagram for correct switch definition.

2.5.2 IP Dome Camera

The protocol that supports the IP Dome Camera is DSCP; refer to the protocol table in the previous section. Set the protocol number to “07” as shown below.

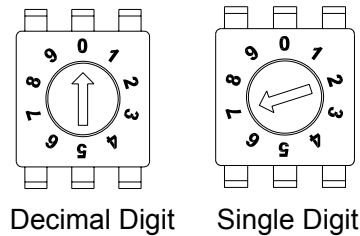

2.6 22-Pin Connector Definition

A Data Cable is shipped with the Integrated High Speed Dome Camera for a quick installation for demo or testing usage. Both the analog and IP Dome Cameras have individual AC 24V cable; see the diagrams in the following subsections. Additionally, the analog and IP Dome Camera’s 22-pin connector definition will also be specified later. For more information about RS-485 connector, see [2.7 RS-485 Connector Definition \(Analog\)](#).

2.6.1 Analog Dome Camera

The analog Dome Camera’s Data Cable is illustrated as shown below.

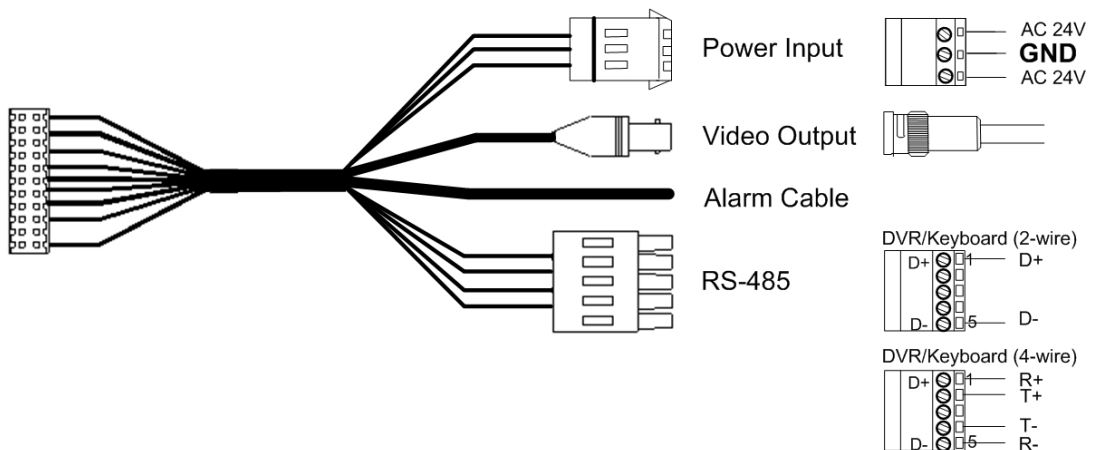

NOTE: Be careful not to pull the cables improperly during installation. Additionally, it is suggested to fasten the cables after cable connection is completed. Furthermore, when wiring the AC 24V power cable, make sure the **Ground** wire is inserted into the mid-pin of the terminal block.

The analog Dome Camera's 22-pin connector definition is listed as shown below.

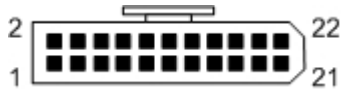

| Pin | Definition | Cable |
|-----|----------------|-------|
| 1 | AC 24-1/DC (+) | 20AWG |
| 2 | ALM NC | |
| 3 | AC 24-2/DC (-) | 20AWG |
| 4 | ALM NO | |
| 5 | FG | 20AWG |
| 6 | ALM COM | |
| 7 | T+ | 24AWG |
| 8 | R- | |
| 9 | T- | |
| 10 | R+ | |
| 11 | ISOG | |

| Pin | Definition | Cable |
|-----|------------|-------|
| 12 | ALM-1 | |
| 13 | ALM-3 | |
| 14 | ALM-2 | |
| 15 | ALM-4 | |
| 16 | ALM-5 | |
| 17 | ALM-6 | |
| 18 | ALM-7 | |
| 19 | ALM-8 | |
| 20 | ALM GND | |
| 21 | VGND | 24AWG |
| 22 | Video | |

2.6.2 IP Dome Camera

The IP Dome Camera's Data Cable is illustrated as shown below.

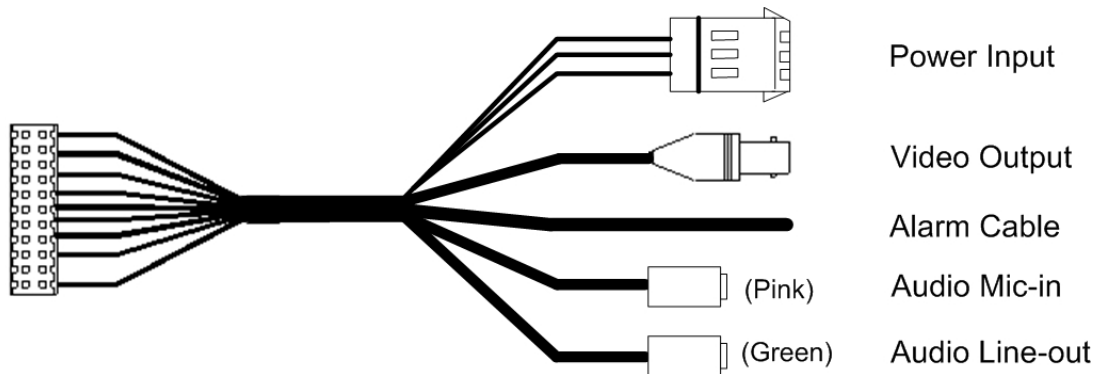

The IP Dome Camera's 22-pin connector definition is listed as shown below.

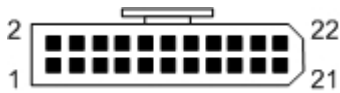

| Pin | Definition | Cable |
|-----|----------------|-------|
| 1 | AC 24-1/DC (+) | 20AWG |
| 2 | ALM NC | |
| 3 | AC 24-2/DC (-) | 20AWG |
| 4 | ALM NO | |
| 5 | FG | 20AWG |
| 6 | ALM COM | |
| 7 | Audio in | 24AWG |
| 8 | Audio out | |
| 9 | Audio GND | |
| 10 | Audio GND | |
| 11 | ISOG | |

| Pin | Definition | Cable |
|-----|------------|-------|
| 12 | ALM-1 | |
| 13 | ALM-3 | |
| 14 | ALM-2 | |
| 15 | ALM-4 | |
| 16 | ALM-5 | |
| 17 | ALM-6 | |
| 18 | ALM-7 | |
| 19 | ALM-8 | |
| 20 | ALM GND | |
| 21 | VGND | 24AWG |
| 22 | Video | |

2.7 RS-485 Connector Definition (Analog)

RS-485 is the interface that communicates the Dome Camera and its control device. Please connect the control keyboard to the Dome Camera through the terminal block. The recommended cables for RS-485 communication are **CAT 5** cables; maximum cable length for over 24-gauge wire is 4000 feet (1219 meters). If the total cable length exceeds 4000 feet, using a repeater to maintain the signals is recommended. Please refer to the figure and table below for pin definition and wiring.



| Pin | Corresponding Pins (22-Pin Connector) | Definition |
|-----|--|-------------|
| 1 | 7,10 | T+, R+ (D+) |
| 2~4 | Reserved | |
| 5 | 8,9 | T-, R- (D-) |

3 Operation and Configuration

3.1 Display Format

The information shown on the screen are described in terms of OSD display, position and function description in the table below.



| Position | Function | OSD Display | Description |
|----------|-------------------------|--|---|
| 1 | Motion | MOTION | Alarm Detect Message |
| 2 | Alarm | ALARM 1 | Alarm Message |
| 3 | Focus Modes & Backlight | A | Auto Focus Mode |
| | | M | Manual Focus Mode |
| | | X | Back Light Compensation OFF |
| | | B | Back Light Compensation ON |
| 4 | Booting Message | XX...(Dome Type) ID: 001 (Default) DSCP/9600 (Default) INITIALIZING | Shows Dome Type, ID Address, Protocol and Baud Rate |
| 5 | Error Message | PAN ERROR TILT ERROE CAM MODULE ERROR | Shows system initializing error message |
| 6 | Zoom Ratio | x1 | Present Zoom Ratio (Optical Zoom/Digital Zoom) |
| 7 | Title | <ul style="list-style-type: none"> Maximum 20 characters for each title. 16 sets of title are available. | |
| 8 | Camera ID | 001 | Show the camera ID |
| 9 | Time | XXXX/XX/XX XX:XX | Year/Month/Day Hour:Minute |

3.2 OSD Menu Tree

The OSD setup menu structures of each model is listed separately in the following section. The star symbol indicates the factory default.

For detailed function description, please see [3.3 Configuration Menu](#).

3.2.1 G/V/T Model

| Item | Layer 1 | Layer 2 | Layer 3 | Default | |
|------------------------|--|--|--|---------|---|
| LANGUAGE | <ENGLISH>, <JAPANESE>, <PORTUGUESE>, <SPANISH>, <FRENCH>, <GERMAN>, <ITALIAN>, <POLISH>, <RUSSIAN>, <TRADITIONAL CHINESE>, <SIMPLIFIED CHINESE>, <TURKISH> | | | ENGLISH | |
| DEFAULT CAMERA | <ON>, <OFF> | | | ON | |
| BACKLIGHT | <ON>, <OFF> | | | OFF | |
| FOCUS | AUTO | AF MODE <NORMAL>, <INTERVAL>, <ZOOM TRIG> EXIT + SAVE: YES | | NORMAL | |
| | MANUAL | FOCUS SPEED <01>~<08> EXIT + SAVE: YES | | | |
| AE MODE | EXPOSURE COMP. | <OFF>, EXPOSURE VALUE: <-10.5dB> ~ <10.5dB> EXIT + SAVE: YES | | OFF | |
| | AE MODE | AUTO | EXIT + SAVE: YES | | ☆ |
| | | BRIGHT | BRIGHT VALUE <00> ~ <31> EXIT + SAVE | | |
| | | SHUTTER | SHUTTER SPEED <1/10000>~<1> SEC. EXIT + SAVE: YES | | |
| | | IRIS | IRIS VALUE <CLOSE>, <F1.6> ~ <F28> EXIT + SAVE: YES | | |
| | | MANUAL | BRIGHT VALUE: AUTO SHUTTER SPEED <1/10000> ~ <1> IRIS VALUE <F1.6> ~ <F28> GAIN VALUE <-3>dB ~ <28>dB EXIT + SAVE: YES | | |
| | EXIT + SAVE | YES | | | |
| | WBC MODE | AUTO (Auto White Balance) | | | ☆ |
| | | INDOOR | | | |
| | | OUTDOOR | | | |
| ATW (Auto-tracing WBC) | | | | | |
| MANUAL | | R GAIN <000> ~ <127> B GAIN <000> ~ <127> EXIT + SAVE: YES | | | |
| SETUP MENU 1 | ZOOM SPEED | <1> ~ <8> | | 8 | |
| | DIGITAL ZOOM | <ON>, <OFF> | | ON | |
| | SLOW SHUTTER | <ON>, <OFF> | | OFF | |
| | IMAGE INVERSE | <ON>, <OFF> | | OFF | |
| | FREEZE | <ON>, <OFF> | | OFF | |
| | APERTURE | <01> ~ <16> | | 11 | |
| | EXIT | YES | | | |
| SETUP MENU 2 | FLIP | <OFF>, <M.E.>, <IMAGE> | | OFF | |
| | ANGLE | MIN ANGLE <-10 ~ +10 DEG> | | 0 | |

| Item | Layer 1 | Layer 2 | Layer 3 | Default |
|----------------------|----------------|---|---------|---------|
| | ADJUSTER | MAX ANGLE <080 ~ 100 DEG> | | 90 |
| | SPEED BY ZOOM | <ON>, <OFF> | | OFF |
| | AUTO CALI. | <ON>, <OFF> | | OFF |
| | SYSTEM RESET | YES | | |
| | EXIT | YES | | |
| ID DISPLAY | <ON>, <OFF> | | | ON |
| TITLE DISPLAY | <ON>, <OFF> | | | OFF |
| TITLE SETTING | <01> ~ <16> | | | 1 |
| PRESET | PRESET SET | <001>~<256> | | ENTER |
| | PRESET RUN | <001>~<256> | | ENTER |
| | EXIT | YES | | ENTER |
| SEQUENCE | SEQUENCE LINE | <1> ~ <8> | | 1 |
| | SEQUENCE POINT | <01> ~ <64> | | 1 |
| | PRESET POS. | <001> ~ <255>, <END> | | 1 |
| | SPEED | <01> ~ <15> | | 1 |
| | DWELL TIME | <000> ~ <127> SEC. | | 0 |
| | RUN SEQUENCE | ENTER | | |
| | EXIT | YES | | |
| AUTOPAN | AUTOPAN LINE | <1> ~ <4> | | 1 |
| | START POINT | <TO FIND>, <TO SAVE> | | |
| | END POINT | <TO FIND>, <TO SAVE> | | |
| | DIRECTION | <RIGHT>, <LEFT> | | RIGHT |
| | SPEED | <01> ~ <04> | | 1 |
| | RUN AUTOPAN | ENTER | | |
| | EXIT | YES | | |
| CRUISE | CRUISE LINE | <1> ~ <8> | | 1 |
| | RECORD START | ENTER | | |
| | RECORD END | ENTER | | |
| | RUN CRUISE | ENTER | | |
| | EXIT | YES | | |
| HOME SETTING | HOME FUNCTION | <ON>, <OFF> | | OFF |
| | SELECT MODE | <PRESET>, <SEQUENCE>, <AUTOPAN>, <CRUISE> | | PRESET |
| | PRESET POINT | <001> ~ <256> | | 1 |
| | SEQUENCE LINE | <1> ~ <8> | | 1 |
| | AUTOPAN LINE | <1> ~ <4> | | 1 |
| | CRUISE LINE | <1> ~ <8> | | 1 |
| | RETURN TIME | <1> ~ <128> MIN. | | 1 |
| | GO | ENTER | | |
| EXIT | YES | | | |
| IR FUNCTION | <AUTO> | THRESHOLD <01> ~ <29> | | AUTO |
| | | EXIT + SAVE: YES | | |
| | <MANUAL> | IR MANUAL: <ON>, <OFF> | | |
| ALARM SETTING | ALARM PIN | <1> ~ <8> | | 1 |
| | ALARM SWITCH | <ON>, <OFF> | | OFF |
| | ALARM TYPE | <NO> (Normal Open), <NC> (Normal Close) | | N.C. |
| | ALARM ACTION | <PRESET>, <SEQUENCE>, <AUTOPAN>, <CRUISE> | | PRESET |
| | PRESET POINT | <001> ~ <256> | | 1 |
| | SEQUENCE LINE | <1> ~ <8> | | 1 |
| | AUTOPAN LINE | <1> ~ <4> | | 1 |
| | CRUISE LINE | <1> ~ <8> | | 1 |
| | DWELL TIME | <001> ~ <127> Sec., <ALWAYS> | | ALWAYS |
| EXIT | YES | | | |
| ALARM DETECT | DETECT SWITCH | <ON>, <OFF> | | OFF |
| | DETECT MODE | ON: <INT FOCUS>, <FIX FOCUS>, <FIX AE>, <MOTION>; OFF: NONE | | |
| | BLOCK MODE | NONE; MOTION: <ON>, <OFF> | | |

| Item | Layer 1 | Layer 2 | Layer 3 | Default | |
|---------------------|----------------|---|----------------------------|---------|---|
| | FRAME SET | NONE; MOTION: <01> ~ <04> | | | |
| | FRAME DISABLE | NONE; MOTION: <01> ~ <04> | | | |
| | THRESHOLD | NONE; MOTION: <001> ~ <255> | | | |
| | EXIT | YES | | | |
| WDR FUNCTION | <ON>, <OFF> | | | OFF | |
| PRIVACY MASK | PRIVACY SWITCH | <ON>, <OFF> | | OFF | |
| | TRANSPARENCY | <ON>, <OFF> | | OFF | |
| | COLOR | <BLACK>, <HI GRAY>, <LO GRAY>, <WHITE>, <RED>, <GREEN>, <BLUE>, <CYAN>, <YELLOW>, <MAGENTA> | | BLACK | |
| | SET MASK | <01> ~ <24> | H CENTER: L/R | | |
| | | | V CENTER: D/U | | |
| | | | H SIZE <000> ~ <080> | | |
| | | | V SIZE <000> ~ <060> | | |
| CLEAR MASK | <01> ~ <24> | | | | |
| EXIT | YES | | | | |
| TIME SETTING | TIME DISPLAY | <ON>, <OFF> | | OFF | |
| | SET YEAR | <00> ~ <99> | | | |
| | SET MONTH | <01> ~ <12> | | | |
| | SET DAY | <00> ~ <31> | | | |
| | SET HOUR | <00> ~ <23> | | | |
| | SET MINUTE | <00> ~ <59> | | | |
| | EXIT+SAVE | | | | |
| SCHEDULE | SWITCH | <ON>, <OFF> | | OFF | |
| | POINT | <01> ~ <32> | | 1 | |
| | HOUR | <00> ~ <23> | | 0 | |
| | MINUTE | <00> ~ <59> | | 0 | |
| | MODE | NONE | NO FUNCTION | | ☆ |
| | | PRESET | PRESET POINT <001> ~ <256> | | |
| | | SEQUENCE | SEQUENCE LINE <1> ~ <8> | | |
| | | AUTOPAN | AUTOPAN LINE <1> ~ <4> | | |
| | | CRUISE | CRUISE LINE <1> ~ <8> | | |
| | IR FUNC. | IR FUNCTION <AUTO>, <ON>, <OFF> | | | |
| SCHEDULE RESET | YES | | | | |
| EXIT | YES | | | | |
| EXIT OSD | YES | | | | |

3.2.2 L/M/R Model

| Item | Layer 1 | Layer 2 | Layer 3 | Default |
|-----------------------|--|---|---------------------------------|---------|
| LANGUAGE | <ENGLISH>, <JAPANESE>, <PORTUGUESE>, <SPANISH>, <FRENCH>, <GERMAN>, <ITALIAN>, <POLISH>, <RUSSIAN>, <TRADITIONAL CHINESE>, <SIMPLIFIED CHINESE>, <TURKISH> | | | ENGLISH |
| DEFAULT CAMERA | <ON>, <OFF> | | | ON |
| BACKLIGHT | <ON> | BLC LEVEL <00> ~ <30> EXIT + SAVE: YES | | OFF |
| | <OFF> | | | |
| FOCUS | AUTO | TUNING VALUE <1.5M> (L Model only), <1M>, <30CM>, <10CM>, <1CM> EXIT + SAVE: YES | | 10CM |
| | MANUAL | FOCUS SPEED <0> ~ <3> EXIT + SAVE: YES | | |
| AE MODE | AUTO | IRIS OFFSET <00> ~ <15> EXIT + SAVE: YES | | ☆ |
| | SHUTTER | SHUTTER SPEED R Model: <1/30000> ~ <1/60> (NTSC); <1/30000> ~ <1/50> (PAL) L/M Model: <1/30000> ~ <1/2> (NTSC); <1/30000> ~ <1/1.5> (PAL) EXIT + SAVE: YES | | |
| | | IRIS | <00> ~ <09> EXIT + SAVE: YES | |
| | AGC | <00> ~ <05> EXIT + SAVE: YES | | |
| WBC MODE | AUTO (Auto White Balance) | | | ☆ |
| | MANUAL | R GAIN <00> ~ <99> B GAIN <00> ~ <99> EXIT + SAVE: YES | | |
| SETUP MENU 1 | ZOOM SPEED | <FAST>, <SLOW> | | FAST |
| | DIGITAL ZOOM | <OFF>, <02> ~ <12> | | OFF |
| | SLOW SHUTTER (L/M Model) | <1/2> ~ <1/60> (NTSC) | | 1/60 |
| | | <1/1.5> ~ <1/50> (PAL) | | 1/50 |
| | IMAGE INVERSE (L/M Model) | <ON>, <OFF> | | OFF |
| | FREEZE (L/M Model) | <ON>, <OFF> | | OFF |
| | APERTURE | <AUTO> | | |
| | <MANUAL> | H APERTURE <00> ~ <31> V APERTURE <00> ~ <31> | | |
| | STABILIZER (L Model Only) | <OFF>, <10Hz>, <5Hz> | | OFF |
| | EXIT | YES | | |
| SETUP MENU 2 | FLIP | <OFF>, <M.E.>, <IMAGE>(L/M Model) | | OFF |
| | ANGLE ADJUSTER | MIN ANGLE <-10 ~ +10 DEG> | | 0 |
| | | MAX ANGLE <080 ~ 100 DEG> | | 90 |
| | SPEED BY ZOOM | <ON>, <OFF> | | OFF |
| | AUTO CALI. | <ON>, <OFF> | | OFF |
| | SYSTEM RESET | YES | | |
| | EXIT | YES | | |
| ID DISPLAY | <ON>, <OFF> | | | ON |
| TITLE DISPLAY | <ON>, <OFF> | | | OFF |
| TITLE SETTING | <01> ~ <16> | | | 1 |
| PRESET | PRESET SET | <001>~<256> | | ENTER |
| | PRESET RUN | <001>~<256> | | ENTER |
| | EXIT | YES | | ENTER |
| SEQUENCE | SEQUENCE LINE | <1> ~ <8> | | 1 |

| Item | Layer 1 | Layer 2 | Layer 3 | Default | |
|----------------------------------|----------------------|---|------------------------|---------|--|
| | SEQUENCE POINT | <01> ~ <64> | | 1 | |
| | PRESET POS. | <001> ~ <255>, <END> | | 1 | |
| | SPEED | <01> ~ <15> | | 1 | |
| | DWELL TIME | <000> ~ <127> SEC. | | 0 | |
| | RUN SEQUENCE | ENTER | | | |
| | EXIT | YES | | | |
| AUTOPAN | AUTOPAN LINE | <1> ~ <4> | | 1 | |
| | START POINT | <TO FIND>, <TO SAVE> | | | |
| | END POINT | <TO FIND>, <TO SAVE> | | | |
| | DIRECTION | <RIGHT>, <LEFT> | | RIGHT | |
| | SPEED | <01> ~ <04> | | 1 | |
| | RUN AUTOPAN | ENTER | | | |
| | EXIT | YES | | | |
| CRUISE | CRUISE LINE | <1> ~ <8> | | 1 | |
| | RECORD START | ENTER | | | |
| | RECORD END | ENTER | | | |
| | RUN CRUISE | ENTER | | | |
| | EXIT | YES | | | |
| HOME SETTING | HOME FUNCTION | <ON>, <OFF> | | OFF | |
| | SELECT MODE | <PRESET>, <SEQUENCE>, <AUTOPAN>, <CRUISE> | | PRESET | |
| | PRESET POINT | <001> ~ <256> | | 1 | |
| | SEQUENCE LINE | <1> ~ <8> | | 1 | |
| | AUTOPAN LINE | <1> ~ <4> | | 1 | |
| | CRUISE LINE | <1> ~ <8> | | 1 | |
| | RETURN TIME | <1> ~ <128> MIN. | | 1 | |
| | GO | ENTER | | | |
| EXIT | YES | | | | |
| IR FUNCTION (L/M Model) | <AUTO>, <ON>, <OFF> | THREADHOLD <MID>, <HI>, <LOW> | | AUTO | |
| | | IR COLOR <B/W>, <COLOR> | | | |
| | | EXIT + SAVE: YES | | | |
| ALARM SETTING | ALARM PIN | <1> ~ <8> | | 1 | |
| | ALARM SWITCH | <ON>, <OFF> | | OFF | |
| | ALARM TYPE | <NO> (Normal Open), <NC> (Normal Close) | | N.C. | |
| | ALARM ACTION | <PRESET>, <SEQUENCE>, <AUTOPAN>, <CRUISE> | | PRESET | |
| | PRESET POINT | <001> ~ <256> | | 1 | |
| | SEQUENCE LINE | <1> ~ <8> | | 1 | |
| | AUTOPAN LINE | <1> ~ <4> | | 1 | |
| | CRUISE LINE | <1> ~ <8> | | 1 | |
| | DWELL TIME | <001> ~ <127> Sec., <ALWAYS> | | ALWAYS | |
| EXIT | YES | | | | |
| ALARM DETECT (L/M Model only) | <ON>, <OFF> | | | OFF | |
| WDR FUNCTION (L/M Model only) | <ON> | RATIO LEVEL <000> ~ <128> SHUTTER SPEED <000> ~ <128> IRIS OFFSET <000> ~ <128> EXIT <YES> | | | |
| | <AUTO> | | | | |
| | <OFF> | | | ☆ | |
| PRIVACY MASK (L/M Model only) | PRIVACY SWITCH | <ON>, <OFF> | | OFF | |
| | MASK SHADE | <GRAY>, <WHITE>, <BLACK> | | BLACK | |
| | SET MASK | <01> ~ <08> | H CENTER <000> ~ <255> | | |
| | | | V CENTER <000> ~ <255> | | |
| | | | H SIZE <000> ~ <127> | | |
| V SIZE <000> ~ <127> | | | | | |
| CLEAR MASK | <01> ~ <08>, <RESET> | | 1 | | |

| Item | Layer 1 | Layer 2 | Layer 3 | Default | |
|--------------|----------------|-----------------|------------------------------------|---------|---|
| | MASK DISPLAY | <FIRST>, <LAST> | | FIRST | |
| | EXIT | YES | | | |
| TIME SETTING | TIME DISPLAY | <ON>, <OFF> | | OFF | |
| | SET YEAR | <00> ~ <99> | | | |
| | SET MONTH | <01> ~ <12> | | | |
| | SET DAY | <00> ~ <31> | | | |
| | SET HOUR | <00> ~ <23> | | | |
| | SET MINUTE | <00> ~ <59> | | | |
| | EXIT+SAVE | | | | |
| | | | | | |
| SCHEDULE | SWITCH | <ON>, <OFF> | | OFF | |
| | POINT | <01> ~ <32> | | 1 | |
| | HOUR | <00> ~ <23> | | 0 | |
| | MINUTE | <00> ~ <59> | | 0 | |
| | MODE | NONE | NO FUNCTION | | ☆ |
| | | PRESET | PRESET POINT <001> ~ <256> | | |
| | | SEQUENCE | SEQUENCE LINE <1> ~ <8> | | |
| | | AUTOPAN | AUTOPAN LINE <1> ~ <4> | | |
| | | CRUISE | CRUISE LINE <1> ~ <8> | | |
| | | IR FUNC. | IR FUNCTION <AUTO>, <ON>, <OFF> | | |
| | SCHEDULE RESET | YES | | | |
| | EXIT | YES | | | |
| | EXIT OSD | YES | | | |

3.2.3 S1/S2 Model

| Item | Layer 1 | Layer 2 | Layer 3 | Default | |
|----------------------------|--|---|--|---------|------|
| LANGUAGE | <ENGLISH>, <JAPANESE>, <PORTUGUESE>, <SPANISH>, <FRENCH>, <GERMAN>, <ITALIAN>, <POLISH>, <RUSSIAN>, <TRADITIONAL CHINESE>, <SIMPLIFIED CHINESE>, <TURKISH> | | | ENGLISH | |
| DEFAULT CAMERA | <ON>, <OFF> | | | ON | |
| BACKLIGHT | <ON>, <OFF> | BLC LEVEL <00> ~ <30> | | OFF | |
| | | EXIT + SAVE: YES | | | |
| FOCUS | AUTO | AF MODE <NORMAL>, <Z. TRIG.>, <PT TRIG.> | | NORMAL | |
| | MANUAL | EXIT+SAVE | | | |
| AE MODE | EXPOSURE COMP. | <OFF>, EXPOSURE VALUE: <-10.5dB> ~ <10.5dB> | | OFF | |
| | AE MODE | AUTO | BRIGHT VALUE; SHUTTER SPEED; IRIS VALUE; GAIN VALUE: AUTO | | AUTO |
| | | | EXIT + SAVE: YES | | |
| | | SHUTTER | SHUTTER SPEED PAL: <1/50> ~ <1/10000> SEC. NTSC: <1/60> ~ <1/10000> SEC. | | |
| | | | EXIT + SAVE: YES | | |
| | | IRIS | IRIS VALUE <F1.6> | | |
| | | | EXIT + SAVE: YES | | |
| | | MANUAL | BRIGHT VALUE: AUTO | | |
| | | | SHUTTER SPEED PAL: <1/50> ~ <1/10000> SEC. NTSC: <1/60> ~ <1/10000> SEC. | | |
| | IRIS VALUE <F1.6> | | | | |
| GAIN VALUE <-3>dB ~ <28>dB | | | | | |
| EXIT+ SAVE | YES | | | | |
| WBC MODE | AUTO (Auto White Balance) | | | ☆ | |
| | INDOOR | | | | |
| | OUTDOOR | | | | |
| | MANUAL | R GAIN <000> ~ <127> | | | |
| | | B GAIN <000> ~ <127> | | | |
| EXIT + SAVE: YES | | | | | |
| SETUP MENU 1 | ZOOM SPEED | <8> | | 8 | |
| | DIGITAL ZOOM | <OFF>, <2x> ~ <12x> | | OFF | |
| | SLOW SHUTTER | <ON>, <OFF> | | OFF | |
| | D.N.R. | 2D N.R. <ON>, <OFF> | | ON | |
| | | 3D N.R. <ON>, <OFF> | | | |
| | | EXIT + SAVE: YES | | | |
| | IMAGE INVERSE | <ON>, <OFF> | | OFF | |
| | FREEZE | <ON>, <OFF> | | OFF | |
| APERTURE | <01> ~ <16> | | 7 | | |
| EXIT | YES | | | | |
| SETUP MENU 2 | FLIP | <OFF>, <M.E.>, <IMAGE> | | OFF | |
| | ANGLE ADJUSTER | MIN ANGLE <-10 ~ +10 DEG> | | 0 | |
| | | MAX ANGLE <080 ~ 100 DEG> | | 90 | |
| | | EXIT + SAVE: YES | | | |
| | SPEED BY ZOOM | <ON>, <OFF> | | OFF | |
| | AUTO CALI. | <ON>, <OFF> | | OFF | |
| | PASSWORD | <ON>, <OFF> | | OFF | |
| OSD AUTO | <OFF>, <5> ~ <30> SEC. | | 20 | | |

| Item | Layer 1 | Layer 2 | Layer 3 | Default |
|----------------------|------------------------------|---|---------|---------|
| | CLOSE | | | |
| | SYSTEM RESET | SYSTEM RESET <YES> | | |
| | | DEFAULT SYSTEM <YES> | | |
| | | EXIT <YES> | | |
| EXIT | YES | | | |
| ID DISPLAY | <ON>, <OFF> | | | ON |
| TITLE DISPLAY | <ON>, <OFF> | | | OFF |
| TITLE SETTING | <01> ~ <16> | | | 1 |
| PRESET | PRESET SET | <001>~<256> | | ENTER |
| | PRESET RUN | <001>~<256> | | ENTER |
| | EXIT | YES | | ENTER |
| SEQUENCE | SEQUENCE LINE | <1> ~ <8> | | 1 |
| | SEQUENCE POINT | <01> ~ <64> | | 1 |
| | PRESET POS. | <001> ~ <255>, <END> | | END |
| | SPEED | <01> ~ <15> | | 1 |
| | DWELL TIME | <000> ~ <127> SEC. | | 0 |
| | RUN SEQUENCE | ENTER | | |
| | EXIT | YES | | |
| AUTOPAN | AUTOPAN LINE | <1> ~ <4> | | 1 |
| | START POINT | <TO FIND>, <TO SAVE> | | |
| | END POINT | <TO FIND>, <TO SAVE> | | |
| | DIRECTION | <RIGHT>, <LEFT> | | RIGHT |
| | SPEED | <01> ~ <04> | | 1 |
| | RUN AUTOPAN | ENTER | | |
| | EXIT | YES | | |
| CRUISE | CRUISE LINE | <1> ~ <8> | | 1 |
| | RECORD START | ENTER | | |
| | RECORD END | ENTER | | |
| | RUN CRUISE | ENTER | | |
| | EXIT | YES | | |
| HOME SETTING | HOME FUNCTION | <ON>, <OFF> | | OFF |
| | SELECT MODE | <PRESET>, <SEQUENCE>, <AUTOPAN>, <CRUISE> | | PRESET |
| | PRESET POINT | <001> ~ <256> | | 1 |
| | SEQUENCE LINE | <1> ~ <8> | | 1 |
| | AUTOPAN LINE | <1> ~ <4> | | 1 |
| | CRUISE LINE | <1> ~ <8> | | 1 |
| | RETURN TIME | <1> ~ <128> MIN. | | 1 |
| | GO | ENTER | | |
| EXIT | YES | | | |
| IR FUNCTION | AUTO | THRESHOLD <MID>, <HI>, <LOW> | | LOW |
| | | EXIT + SAVE: YES | | |
| | MANUAL | IR MANUAL: <ON>, <OFF> | | |
| | | EXIT + SAVE: YES | | |
| ALARM SETTING | ALARM PIN | <1> ~ <8> | | 1 |
| | ALARM SWITCH | <ON>, <OFF> | | OFF |
| | ALARM TYPE | <NO> (Normal Open), <NC> (Normal Close) | | N.C. |
| | ALARM ACTION | <PRESET>, <SEQUENCE>, <AUTOPAN>, <CRUISE> | | PRESET |
| | PRESET POINT | <001> ~ <256> | | 1 |
| | SEQUENCE LINE | <1> ~ <8> | | 1 |
| | AUTOPAN LINE | <1> ~ <4> | | 1 |
| | CRUISE LINE | <1> ~ <8> | | 1 |
| DWELL TIME | <001> ~ <127> Sec., <ALWAYS> | | ALWAYS | |
| EXIT | YES | | | |
| ALARM DETECT | <NONE> | | | |
| WDR FUNCTION | <NONE> | | OFF | |
| PRIVACY MASK | PRIVACY | <ON>, <OFF> | | OFF |

| Item | Layer 1 | Layer 2 | Layer 3 | Default | |
|---------------------|----------------|---|------------------------------------|----------------------------|---|
| | SWITCH | | | | |
| | TRANSPARENCY | <ON>, <OFF> | | OFF | |
| | COLOR | <BLACK>, <WHITE>, <RED>, <GREEN>, <BLUE>, <CYAN>, <YELLOW>, <MAGENTA> | | BLACK | |
| | SET MASK | <01> ~ <16> | H CENTER: L/R | | |
| | | | V CENTER: D/U | | |
| | | | H SIZE <000> ~ <080> | 0 | |
| | | | V SIZE <000> ~ <060> | 0 | |
| EXIT + SAVE | | | | | |
| CLEAR MASK | <01> ~ <16> | | 1 | | |
| EXIT | YES | | | | |
| TIME SETTING | TIME DISPLAY | <ON>, <OFF> | | OFF | |
| | SET YEAR | <00> ~ <99> | | | |
| | SET MONTH | <01> ~ <12> | | | |
| | SET DAY | <00> ~ <31> | | | |
| | SET HOUR | <00> ~ <23> | | | |
| | SET MINUTE | <00> ~ <59> | | | |
| | EXIT+SAVE | | | | |
| SCHEDULE | SWITCH | <ON>, <OFF> | | OFF | |
| | POINT | <01> ~ <32> | | 1 | |
| | HOUR | <00> ~ <23> | | 0 | |
| | MINUTE | <00> ~ <59> | | 0 | |
| | MODE | NONE | | NO FUNCTION | ☆ |
| | | PRESET | | PRESET POINT <001> ~ <256> | |
| | | SEQUENCE | | SEQUENCE LINE <1> ~ <8> | |
| | | AUTOPAN | | AUTOPAN LINE <1> ~ <4> | |
| | | CRUISE | | CRUISE LINE <1> ~ <8> | |
| | IR FUNC. | | IR FUNCTION <AUTO>, <ON>, <OFF> | | |
| | SCHEDULE RESET | YES | | | |
| EXIT | YES | | | | |
| EXIT OSD | YES | | | | |

3.3 Configuration Menu

The detailed functions and parameter settings of your Speed Dome Camera can be set through the OSD (On Screen Display) menu with a control device, such as a control keyboard. The items in each model's OSD menu are described in the following sections.

To enter the OSD menu of the selected camera, press the <CAMERA MENU> key on the control keyboard and hold it for 3 seconds to enter the OSD menu.

To select the setup item, use direction keys on a keyboard to move the OSD cursor in the OSD menu.

To setup items, use direction keys on a keyboard to move the OSD cursor in the OSD menu. For items with →, press right/left direction keys on the control keyboard to select. For items with ↓, press the <CAMERA MENU> key on the control keyboard to enter their sub menus. For items with →↓, users can use the right/left direction key to select functions, and then press the <CAMERA MENU> key on the control keyboard to enter their sub menus.

For further detailed setup procedures, please refer to the user's manual of your installed control devices.



NOTE: In the Camera OSD menu, the <CAMERA MENU> key functions as "ENTER" and "EXIT."

During the Dome Camera's start-up, the **OSD Start Page** will display information including ID number, protocol/baudrate and camera initializing message. Furthermore, when some camera errors occur, the error message(s) will be shown on the screen. If the problem(s) cannot be solved at once, please contact your supplier for assistance.

3.3.1 LANGUAGE

The camera supports multi-language OSD operation; the available languages include English, Japanese, Portuguese, Spanish, French, German, Italian, Polish, Russian, Traditional Chinese, Simplified Chinese and Turkish. You can straight set a wanted language on the **MAIN PAGE 1**, as shown below. As you select a language with the arrow keys, the OSD will automatically change to the language you selected. The default language is <ENGLISH>.

| MAIN PAGE 1 | |
|----------------|---------|
| LANGUAGE | ENGLISH |
| DEFAULT CAMERA | ON |
| BACKLIGHT | OFF |
| FOCUS | AUTO |
| AE MODE | ENTER |
| WBC MODE | AUTO |
| SETUP MENU 1 | ENTER |
| SETUP MENU 2 | ENTER |

3.3.2 DEFAULT CAMERA

The DEFAULT CAMERA option is used to restore some camera settings back to default setting. The settings that are affected include Backlight, Focus, AE, WBC, Aperture, Zoom Speed and Digital Zoom. Once any one of the items is modified, the setting will become <OFF> automatically. Select <ON> for this item to recall the mentioned camera parameters.



NOTE: Zoom Speed and Digital Zoom will be restored to factory defaults only in F and U models.

3.3.3 BACKLIGHT

The Backlight compensation function prevents the center object from being too dark in surroundings where excessive light is behind the object.

G/V/T/S1/S2 Model:

Select <ON> to activate the function; the center object will be brightened in contrast to the edge of the picture (where a backlight would be most likely located).

After completing setup of backlight, go back to the **Main Page 1** and continue to set the focus relevant values.

| MAIN PAGE 1 | |
|----------------|---------|
| LANGUAGE | ENGLISH |
| DEFAULT CAMERA | ON |
| BACKLIGHT | OFF |
| FOCUS | AUTO |
| AE MODE | ENTER |
| WBC MODE | AUTO |
| SETUP MENU 1 | ENTER |
| SETUP MENU 2 | ENTER |

L/M/R Model:

The Backlight Compensation Level ranges from 00 to 30.

| | |
|-------------|-----|
| BLC LEVEL | 00 |
| EXIT + SAVE | YES |



NOTE: If this function is enabled, the WDR function (for L and M models) will be disabled automatically. For details, refer to section [3.3.20 WDR FUNCTION](#).

After completing setup of backlight, go back to the **Main Page 1** and continue to set the focus values.

| MAIN PAGE 1 | |
|----------------|---------|
| LANGUAGE | ENGLISH |
| DEFAULT CAMERA | ON |
| BACKLIGHT | OFF |
| FOCUS | AUTO |
| AE MODE | AUTO |
| WBC MODE | AUTO |
| SETUP MENU 1 | ENTER |
| SETUP MENU 2 | ENTER |

3.3.4 FOCUS

The focus of the Dome Camera can be operated in two modes: Auto Focus mode and Manual Focus mode. Various setting for different models are described as follows.

G/V/T Model:

- **AUTO**

The optimum focus is achieved by the internal digital circuit. There are 3 modes for users to select for different conditions.

Normal AF (Auto Focus) Mode: The Dome Camera will automatically adjust the focus of the picture.

Zoom Trigger Mode: When users press the TELE or the WIDE keys on a control keyboard or other control devices to change the zoom, the Dome Camera will automatically adjust its focus after a period of time (the factory default value is five seconds) until the commands of TELE/WIDE is terminated.

Interval AF Mode: The mode is used for AF movements carried out at particular intervals. If users pan/tilt the Dome Camera, the camera will focus automatically after a period of time; the initial value is five seconds.

- **MANUAL**

In this focus mode, users can adjust the focus speed, ranging from 01 ~ 08.

| | |
|-------------|-----|
| FOCUS SPEED | 01 |
| EXIT + SAVE | YES |

After completing setup of focus, go back to the **Main Page 1** and continue to set the AE mode.

| MAIN PAGE 1 | |
|----------------|---------|
| LANGUAGE | ENGLISH |
| DEFAULT CAMERA | ON |
| BACKLIGHT | OFF |
| FOCUS | AUTO |
| AE MODE | ENTER |
| WBC MODE | AUTO |
| SETUP MENU 1 | ENTER |
| SETUP MENU 2 | ENTER |

L/M/R Model:

- **AUTO**

The optimum focus is achieved by the internal digital circuit. Users can adjust the minimum auto focus range for some special conditions; the options include <1.5 m> (L model only), <1 m>, <30 cm>, <10 cm> and <1 cm>.

| | |
|--------------|------|
| TUNING VALUE | 10CM |
| EXIT + SAVE | YES |

- **MANUAL**

In this focus mode, users can adjust the focus speed, ranging from 0 ~ 3.

| | |
|-------------|-----|
| FOCUS SPEED | 0 |
| EXIT + SAVE | YES |

After completing setup of focus, go back to the **Main Page 1** and continue to set the AE mode.

| | |
|----------------|---------|
| MAIN PAGE 1 | |
| LANGUAGE | ENGLISH |
| DEFAULT CAMERA | ON |
| BACKLIGHT | OFF |
| FOCUS | AUTO |
| AE MODE | AUTO |
| WBC MODE | AUTO |
| SETUP MENU 1 | ENTER |
| SETUP MENU 2 | ENTER |

S1/S2 Model:

- **AUTO**

There are three options available for the AF Mode, including Normal mode, Zoom Trigger (Z. TRIG.) mode and PT Trigger (PT TRIG.) mode. The submenu of AF Mode is shown below:

| | |
|-------------|--------|
| AF MODE | NORMAL |
| EXIT + SAVE | YES |

Normal Mode

In this mode, the camera will keep in focus automatically and continuously in any condition.

Zoom Trigger Mode

In this mode, AF is activated at the time when zoom is changed.

PT Trigger Mode

In this mode, AF is triggered when the Dome Camera is manipulated to pan, tilt or zoom.

EXIT + SAVE

Press <YES> on this item to save the selected AF Mode.

- **MANUAL**

In this mode, users can adjust focus near/far via the control keyboard's Focus Near/Far key.

After completing setup of focus, go back to the **Main Page 1** and continue to set the AE mode.

| MAIN PAGE 1 | |
|----------------|---------|
| LANGUAGE | ENGLISH |
| DEFAULT CAMERA | ON |
| BACKLIGHT | OFF |
| FOCUS | AUTO |
| AE MODE | ENTER |
| WBC MODE | AUTO |
| SETUP MENU 1 | ENTER |
| SETUP MENU 2 | ENTER |



NOTE: For all models, the AF mode will be resumed after every boot.

3.3.5 AE MODE

The exposure is the amount of light received by the image sensor and is determined by the width of lens diaphragm opening (iris adjustment), the amount of exposure by the sensor (shutter speed) and other exposure parameters. With this item, users can define how the Auto Exposure (AE) function works.

G/V/T Model:

- **EXPOSURE COMPENSATION**

The exposure value ranges from -10.5dB ~ 10.5dB. Select <OFF> to disable the function.



NOTE: For G/V/T models, this function can be adjusted through <Brightness>/<Iris> key on the control keyboard.

- **AE MODE**

- **AUTO**

In this mode, the camera's Brightness, Shutter Speed, IRIS and AGC (Auto Gain Control) control circuits work together automatically to get consistent video output level.



NOTE: For G/V/T models, if not in **AUTO** exposure mode, IR cut filter cannot automatically switch to Day/Night mode.

- **BRIGHT**

The brightness control function adjusts IRIS and AGC using an internal algorithm. Brightness is controlled by gain when the light condition is dark and by iris when the light condition is bright. The bright value ranges from 00 ~ 31.

- **SHUTTER**

With this option, SHUTTER speed takes main control of exposure, and both IRIS and AGC will function automatically in cooperation with shutter speed to achieve consistent exposure output. The range of shutter speed is from 1/10000 ~ 1.

- **IRIS**

With this option, the IRIS function adjusts exposure in higher property. SHUTTER speed and AGC circuit will function automatically in cooperating with IRIS to get consistent exposure output. The opening of a

lens controls the amount of light reaching to the surface of the selected device. By increasing the F-stop number (F1.6, F2, F2.4, etc.), less light is permitted to pass; options range from F1.6 ~ F28.

MANUAL

In the mode, users can adjust shutter speed (1/10000 ~ 1), iris value (F1.6 ~ F28) and gain value (-3dB ~ 28dB).

- **EXIT**

Exit the AE MODE menu and go back to the **Main Page 1** to continue to set the WBC mode.

| MAIN PAGE 1 | |
|----------------|---------|
| LANGUAGE | ENGLISH |
| DEFAULT CAMERA | ON |
| BACKLIGHT | OFF |
| FOCUS | AUTO |
| AE MODE | ENTER |
| WBC MODE | AUTO |
| SETUP MENU 1 | ENTER |
| SETUP MENU 2 | ENTER |

L/M/R Model:

- **AUTO**

In this mode, the camera's Shutter, IRIS and AGC control function work automatically to compensate the light exposure of image sensor for consistent video output level. IRIS OFFSET is used to set the level of IRIS variation (00 ~ 15); it can also be adjusted through <Brightness>/<Iris> key on the control keyboard.

- **SHUTTER**

With this option, the priority of SHUTTER is higher than IRIS and AGC; IRIS and AGC circuit will function automatically in cooperating with SHUTTER to get consistent exposure. The range of shutter speed for L and M models is: 1/30000 ~ 1/2 and for R model: 1/30000 ~ 1/50 (PAL) or 1/60 (NTSC).

- **IRIS**

With this option, the priority of IRIS is higher than SHUTTER and AGC; SHUTTER and AGC circuit will function automatically in cooperating with IRIS to get consistent exposure. The range of Iris level is between 00 and 09.

- **AGC**

With this option, the priority of AGC is higher than SHUTTER and IRIS; SHUTTER and IRIS circuit will function automatically in cooperating with AGC to get consistent exposure. The range of AGC level is between 00 and 05.



NOTE: For L and M models, if AE MODE is set as SHUTTER, IRIS or AGC mode rather than AUTO mode, the following functions will be turned off automatically: WDR, Digital Slow Shutter and Alarm Detect. Additionally, when WDR/Alarm Detect is turned on, AE MODE will become **AUTO**. In the same situation, if the camera's IR function was set as IR AUTO mode, it will become invalid even though the OSD display remains the same.

After completing various parameter setups, please exit the AE MODE menu and go back to the **Main Page 1** to continue to set the WBC mode.

| MAIN PAGE 1 | |
|----------------|---------|
| LANGUAGE | ENGLISH |
| DEFAULT CAMERA | ON |
| BACKLIGHT | OFF |
| FOCUS | AUTO |
| AE MODE | AUTO |
| WBC MODE | AUTO |
| SETUP MENU 1 | ENTER |
| SETUP MENU 2 | ENTER |

S1/S2 Model:

- **EXPOSURE COMPENSATION**

The exposure value ranges from -10.5dB ~ 10.5dB. Select <OFF> to disable the function.

- **AE MODE**

AUTO

In this mode, the camera's Brightness, Shutter Speed, IRIS and AGC (Auto Gain Control) control circuits work together automatically to get consistent video output level.

SHUTTER

With this option, Shutter Speed takes main control of exposure, and both IRIS and AGC will function automatically in cooperation with shutter speed to achieve consistent exposure output. The shutter speed ranges from 1/10000 ~ 1/50.

IRIS

In this mode, the IRIS function adjusts exposure in higher property. SHUTTER speed and AGC circuit will function automatically in cooperating with IRIS to get consistent exposure output. The IRIS value is fixed at f1.6.

Manual

In the mode, users can adjust shutter speed (1/10000 ~ 1/50 for PAL; 1/10000 ~ 1/60 for NTSC) and gain value (-3dB ~ 28dB) for optimized video output.

- **EXIT**

Exit the AE MODE menu and go back to the **Main Page 1** to continue to set the WBC mode.

| MAIN PAGE 1 | |
|----------------|---------|
| LANGUAGE | ENGLISH |
| DEFAULT CAMERA | OFF |
| BACKLIGHT | OFF |
| FOCUS | AUTO |
| AE MODE | ENTER |
| WBC MODE | AUTO |
| SETUP MENU 1 | ENTER |
| SETUP MENU 2 | ENTER |

3.3.6 WBC MODE

A digital camera needs to find reference color temperature, which is a way of measuring the quality of a light source, for calculating all the other colors. The unit for measuring this ratio is in degree Kelvin (K). You can select one of the White Balance Control modes according to the condition. The following table shows the color temperature of some light sources.

| Light Sources | Color Temperature in K |
|------------------------|------------------------|
| Cloudy Sky | 6,000 to 8,000 |
| Noon Sun and Clear Sky | 6,500 |
| Household Lighting | 2,500 to 3,000 |
| 75-watt Bulb | 2,820 |
| Candle Flame | 1,200 to 1,500 |

G/V/T/S1/S2 Model:

- **AUTO**
In this mode, white balance works within its color temperature range. This mode computes the white balance value output using color information from the entire screen. It outputs the proper value using the color temperature radiating from a black subject based on a range of values from 3000K to 7500K.

- **INDOOR**
3200 K Base mode.

- **OUTDOOR**
5800 K Base mode.

- **ATW (Auto Tracing White Balance)**
The Dome Camera takes out the signals in a screen in the range from 2000 K to 10000 K.

- **MANUAL**
In this mode, users can change the White Balance value manually; R gain and B gain are adjustable and range from 000 to 127.

| WBC MENU | |
|-----------|-----|
| R GAIN | 050 |
| B GAIN | 050 |
| EXIT+SAVE | YES |

After WBC relevant parameter setups are completed, please exit the WBC MODE menu and go back to the **Main Page 1** to continue to set other functions under the Setup Menu 1.

| MAIN PAGE 1 | |
|----------------|---------|
| LANGUAGE | ENGLISH |
| DEFAULT CAMERA | ON |
| BACKLIGHT | OFF |
| FOCUS | AUTO |
| AE MODE | ENTER |
| WBC MODE | AUTO |
| SETUP MENU 1 | ENTER |
| SETUP MENU 2 | ENTER |

L/M/R Model:

- **AUTO**

In this mode, white balance works within its color temperature range and calculates the best-fit white balance.

- **MANUAL**

In this mode, users can change the White Balance value manually; adjustable R gain and B gain range from 00 to 99.

| WBC MENU | |
|-------------|-----|
| R GAIN | 50 |
| B GAIN | 50 |
| EXIT + SAVE | YES |

After WBC relevant parameter setups are completed, please exit the WBC MODE menu and go back to the **Main Page 1** to continue to set other functions under the Setup Menu 1.

| MAIN PAGE 1 | |
|----------------|---------|
| LANGUAGE | ENGLISH |
| DEFAULT CAMERA | ON |
| BACKLIGHT | OFF |
| FOCUS | AUTO |
| AE MODE | AUTO |
| WBC MODE | AUTO |
| SETUP MENU 1 | ENTER |
| SETUP MENU 2 | ENTER |

3.3.7 SETUP MENU 1

In Setup Menu 1, users could set Zoom Speed and choose whether to activate functions including Digital Zoom, Slow Shutter, Noise Reduction, Image Inverse and Image Freeze. Refer to the following description for use of each function.

G/V/T Model:

| SETUP MENU 1 | |
|---------------|-----|
| ZOOM SPEED | 8 |
| DIGITAL ZOOM | ON |
| SLOW SHUTTER | OFF |
| IMAGE INVERSE | OFF |
| FREEZE | OFF |
| APERTURE | 11 |
| EXIT | YES |

L Model:

| SETUP MENU 1 | |
|---------------|------|
| ZOOM SPEED | FAST |
| DIGITAL ZOOM | OFF |
| SLOW SHUTTER | OFF |
| IMAGE INVERSE | OFF |
| FREEZE | OFF |
| APERTURE | AUTO |
| STABILIZER | OFF |
| EXIT | YES |

M Model:

| SETUP MENU 1 | |
|---------------|------|
| ZOOM SPEED | FAST |
| DIGITAL ZOOM | OFF |
| SLOW SHUTTER | OFF |
| IMAGE INVERSE | OFF |
| FREEZE | OFF |
| APERTURE | AUTO |
| EXIT | YES |

R Model:

| SETUP MENU 1 | |
|---------------|------|
| ZOOM SPEED | FAST |
| DIGITAL ZOOM | OFF |
| SLOW SHUTTER | NONE |
| IMAGE INVERSE | NONE |
| FREEZE | NONE |
| APERTURE | AUTO |
| EXIT | YES |

S1/S2 Model:

| SETUP MENU 1 | |
|---------------|-------|
| ZOOM SPEED | 8 |
| DIGITAL ZOOM | OFF |
| SLOW SHUTTER | OFF |
| D.N.R. | ENTER |
| IMAGE INVERSE | OFF |
| FREEZE | OFF |
| APERTURE | 07 |
| EXIT | YES |

- **ZOOM SPEED**

This item is used to set the zoom speed of the Dome Camera.

G/V/T Model:

For these models, the zoom speed value ranges from <1> (slow) to <8> (fast). The default value is <8>.

L/M/R Model:

For the three models, the options are <FAST> (default) and <SLOW>.

S1/S2 Model:

Zoom speed is fixed at <8>.

- **DIGITAL ZOOM**

With this item, users can enable or disable the 12× Digital Zoom. The Digital Zoom will be activated after the full Optical Zoom level is reached.



NOTE: The difference between optical and digital zoom is that optical zoom uses the lens within the camera to draw the image closer via zoom in or out to achieve the desired effect. Optical zoom remains the same quality and full resolution of the zoomed image. On the other hand, Digital zoom takes a portion of an image and expands the partial image to the full size of the original image; therefore, the image quality will be reduced.

G/V/T/S1/S2 Model:

For these models, maximum 12× digital zoom function is allowed to be enabled. The default setting is <ON>.

L/M/R/S1/S2 Model:

For the three models, Digital zoom ratio is adjustable from <02> to <12>. The default setting is <OFF>. For L model, if Image Stabilization function is turned on, it will limit the effect of Digital Zoom.

- **SLOW SHUTTER**

The shutter speed determines how long the image sensor is exposed to light. To see clear image in a dark environment, please enable Digital Slow Shutter function and select a slower shutter speed.

G/V/T/S1/S2 Model:

As enable the Digital Slow Shutter function, the Dome Camera will automatically adjust the shutter speed basing on the light condition of installation environment. It enables users to see objects in a dark environment under 0.1 lux.

L/M Model:

The shutter speed is adjustable in L and M models. With the slowest shutter speed, users can see objects in a dark environment under 0.1 lux or see smooth video image with a higher shutter speed. The options are from <1/2> to <1/60> for NTSC and <1/1.5> to <1/50> for PAL.



NOTE: For L and M models, the Digital Slow Shutter function is conditional on 1) shutter speed: > 1/50 or 1/60; 2) in AE AUTO mode; 3) Image Stabilizer function is OFF.

- **DIGITAL NOISE REDUCTION (S1/S2 Model)**

With 2D / 3D Digital Noise Reduction (D.N.R.), the processor analyzes pixel by pixel and frame by frame to eliminate environmental noise signal so that the highest quality image can be produced even in low light conditions. In comparison with 2D D.N.R., 3D D.N.R generates better denoising effects.

- **IMAGE INVERSE (Excluding R Model)**

Users can select <ON> to make the displayed image inversed vertically and horizontally (see the figures shown below). Occasions to employ the function include conferences, demonstration, testing, etc. The default setting is <OFF>.

Application: Users can see the displayed images, as shown below, when a Dome Camera is placed on the desk top in a conference, for instance.

IMAGE INVERSE (OFF)

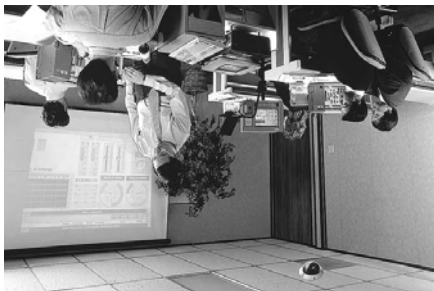

IMAGE INVERSE (ON)



NOTE: When Image Inverse function is enabled, the privacy mask(s) will be set off automatically (see [3.3.21 PRIVACY MASK](#)). For L and M models, if WDR (see [3.3.20 WDR FUNCTION](#)) is set as **ON**, all the parameters of WDR will have no effect unless Image Inverse is turned off.

- **FREEZE (Excluding R Model)**

Freeze function allows to hold the image while the camera is moving between preset positions such as in PRESET (see section 3.3.12) and SEQUENCE (see section 3.3.13) modes. For example, when the Dome Camera is manipulated to run from point A to point B, if the Freeze function is activated, the first view that users would see is point A. Then the next view would directly change to point B, without displaying the moving path.

- **APERTURE**

Under this setup menu, users can adjust enhancement of the edges of objects in the picture.

G/V/T/S1/S2 Model:

There are 16 levels of adjustment; the options are <01> ~ <16>; <01> represents “no enhancement”. When shooting text, this function could make it sharp.

L/M/R Model:

Users can select either the <AUTO> mode or <MANUAL> mode. Under the <MANUAL> mode, the parameters of H aperture and V aperture are adjustable, ranging from 00 to 31.

| APERTURE MENU | |
|---------------|-----|
| H APERTURE | 00 |
| V APERTURE | 00 |
| EXIT+SAVE | YES |

- **STABILIZER (L Model)**

With the Image Stabilizer Function, the speed Dome Camera can capture images that would otherwise be blurred due to the vibration. The built-in electronic compensation filters out the vibrations of up to 80% movement at 10Hz, as caused by wind and other environmental conditions. Its various detection mode ensures total detection for all types of environment. If the function is activated, users could select the frequency range of either 10Hz or 5 Hz.



NOTE: If the function is turned on, it will result in 1) WDR function: OFF; 2) Digital Slow Shutter: no function; 3) limitation in Digital Zoom capability.

- **EXIT**

Exit the SETUP MENU 1 and go back to the **MAIN PAGE 1** to set other functions under the Setup Menu 1.

G/V/T/S1/S2 Model:

| MAIN PAGE 1 | |
|----------------|---------|
| LANGUAGE | ENGLISH |
| DEFAULT CAMERA | ON |
| BACKLIGHT | OFF |
| FOCUS | AUTO |
| AE MODE | ENTER |
| WBC MODE | AUTO |
| SETUP MENU 1 | ENTER |
| SETUP MENU 2 | ENTER |

L/M/R Model:

| MAIN PAGE 1 | |
|----------------|---------|
| LANGUAGE | ENGLISH |
| DEFAULT CAMERA | ON |
| BACKLIGHT | OFF |
| FOCUS | AUTO |
| AE MODE | AUTO |
| WBC MODE | AUTO |
| SETUP MENU 1 | ENTER |
| SETUP MENU 2 | ENTER |

3.3.8 **SETUP MENU 2**

G/V/T/L/M/R Model:

| SETUP MENU 2 | |
|----------------|-------|
| FLIP | ENTER |
| ANGLE ADJUSTER | ENTER |
| SPEED BY ZOOM | OFF |
| AUTO CALI. | OFF |
| SYSTEM RESET | YES |
| EXIT | YES |

S1/S2 Model:

| SETUP MENU 2 | |
|----------------|--------|
| FLIP | ENTER |
| ANGLE ADJUSTER | ENTER |
| SPEED BY ZOOM | OFF |
| AUTO CALI. | OFF |
| PASSWORD | OFF |
| OSD AUTO CLOSE | 20 SEC |
| SYSTEM RESET | ENTER |
| EXIT | YES |

- **FLIP**

Users can track an object continuously when it passes through under the Dome Camera with setting Flip to IMAGE (digital flip) or M.E. (mechanical flip).

| FLIP SETTING | |
|--------------|-----|
| FLIP | OFF |
| EXIT | YES |

IMAGE (Excluding R Model)

IMAGE represents digital IMAGE FLIP, which enables users to keep tracking objects seamlessly; under the mode, almost no delay occurs in comparing with that under the M.E. mode.



NOTE: The Privacy Mask function will be automatically disabled if the Image Flip function is enabled, and the screen will show “MASK WILL BE SET OFF.”

M.E. (Mechanical Flip)

M.E. is a standard mechanical operation. As the Dome Camera tilts to the maximum angle, it will pan 180°, and then continue tilting to keep tracking objects.



NOTE: Flip setting is manual-controlled only. If a Preset or a point for other function (ex. Sequence) is set in the position that can only be reached through FLIP motion, when Flip is off, the position cannot be reached anymore.

OFF

Select this item to disable the flip function.



NOTE: To make the Dome Camera tilt between a specific range, such as -10° to +100° or -10° ~ +190°, please go to **ANGLE ADJUSTER** (see next section) to set the angle range of tilt. Otherwise, the Dome Camera will tilt 90° as the default setting.

- **ANGLE ADJUSTER**

The item is for adjusting the angle range of tilt motion. The Range of the tilt motion varies in different FLIP modes: the angle ranges from -10° to +100° in the M.E. FLIP and FLIP OFF modes, and from -10° ~ +190° in the IMAGE FLIP mode.

| | |
|------------------|--------|
| ANGLE ADJUSTER | |
| ADJUST MIN ANGLE | -10DEG |
| ADJUST MAX ANGLE | 100DEG |
| EXIT + SAVE | YES |

- **SPEED BY ZOOM**

If the item is set to <ON>, the pan/tilt speed will be automatically adjusted by internal algorithm when zooming. The larger zoom ratio leads to the lower rotating speed.

- **AUTO CALI. (Auto Calibration)**

There are one horizontal point and one vertical infrared rays check point in each Dome Camera. During installation or maintenance, the Dome Camera's position may be moved. Therefore, the relative distance between the original set point and the check point will be changed. If the Auto Calibration function is enabled, the Dome Camera will automatically detect the matter and reset the horizontal point back to the original position.

- **PASSWORD (S1/S2 Model)**

The administrator can activate OSD Password function for security concerns. Once the function is turned on, users are required to enter the password every time when accessing to the OSD menu. The Password setting menu is shown below:



The password setting procedure is like the following:

STEP 1: Choose a number with direction keys and then press the **<CAMERA MENU>** key (ENTER) to input. For example: **<0> <CAMERA MENU>**, **<1> <CAMERA MENU>**, **<2> <CAMERA MENU>**, **<3> <CAMERA MENU>**.

PASSWORD: 0123

STEP 2: In the second line, enter the same password again to confirm the setting.

STEP 3: Move the cursor to **<SAVE>** and press **<CAMERA MENU>** to save the setting.

STEP 4: Move the cursor to **<EXIT>** and press **<CAMERA MENU>** to exit the password setting page.

If OSD Password function is enabled, when press the **<CAMERA MENU>** key to enter the OSD menu, the password request message will be displayed as shown below. Please enter the password, press **<ENTER>** and then access to the OSD main menu.

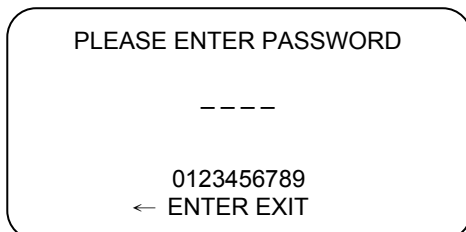

- **OSD AUTO CLOSE (S1/S2 Model)**

Users can specify the duration for OSD menu to stay on the screen. Time selection ranges from 5 ~ 30 seconds. To keep the OSD menu stay on the screen, please set this option to "OFF".

- **SYSTEM RESET**

G/V/T/L/M/R Model:

Select this item for system reboot.

S1/S2 Model:

Two types of system reset can be implemented under this item:

SYSTEM RESET

Select this function for system reboot. Press "ENTER" and system reboot will start up.

DEFAULT SYSTEM

This function allows users to restore the camera to its factory default state. Press "ENTER" and reset will start up.

- **EXIT**

Exit the SETUP MENU 2 and go back to the **MAIN PAGE 1**. Then go to the **MAIN PAGE 2** to carry on setting other functions.

| MAIN PAGE 2 | |
|---------------|-------|
| ID DISPLAY | ON |
| TITLE DISPLAY | OFF |
| TITLE SETTING | 01 |
| PRESET | ENTER |
| SEQUENCE | ENTER |
| AUTOPAN | ENTER |
| CRUISE | ENTER |
| HOME SETTING | ENTER |

3.3.9 ID DISPLAY

Press the direction key down to turn the MAIN MENU page from 1 to 2, and then the menu item <ID DISPLAY> will be shown on the top. Users are allowed to choose whether the Dome Camera's ID will be displayed on screen for identification. For more information, please refer to [2.4 ID Setting](#).

- **ON**
Display the ID address of the selected Dome Camera on the right bottom of the screen.
- **OFF**
Hide the ID address of the selected Dome Camera.

3.3.10 TITLE DISPLAY

Users are allowed to name a view area, where the title will be displayed on screen for easy recognition.

- **ON**
Select <ON> to display the title set for a view area on screen while the camera shooting the view area.
- **OFF**
When **TITLE DISPLAY** is set <OFF>, no title will be displayed on screen even titles have been set in advance.

3.3.11 TITLE SETTING

Up to 16 zone titles can be set with maximum 20 characters for each title.

Follow the steps to set a camera title.

STEP 1: Operate the Dome Camera to a view area where you want to set a title for it.

STEP 2: Turn on the OSD and go to the **MAIN PAGE 2** to select <TITLE SETTING>.

STEP 3: Select a number to represent the view area.

STEP 4: Press the <**CAMERA MENU**> key (ENTER) on the keyboard to go into the editing page.

| TITLE SETTING: 01 | | | | | | | | | | |
|-------------------|---|---|---|---|---|---|---|---|---|--------|
| 0 | 1 | 2 | 3 | 4 | 5 | 6 | 7 | 8 | 9 | EXIT |
| A | B | C | D | E | F | G | H | I | J | SAVE |
| K | L | M | N | O | P | Q | R | S | T | LEFT |
| U | V | W | X | Y | Z | : | / | . | , | RIGHT |
| [|] | + | ? | - | | | | | | DELETE |
| TITLE: ABC | | | | | | | | | | |

STEP 5: Choose a character with direction keys and then press the **<CAMERA MENU>** key (ENTER) to input. For example: **<A> <CAMERA MENU>**, ** <CAMERA MENU>**, **<C> <CAMERA MENU>**
TITLE: ABC

STEP 6: To delete input characters, move the cursor to **<LEFT>** or **<RIGHT>** and press **<CAMERA MENU>** to select a character in the entry field. Then move the cursor to **<DELETE>** and press **<CAMERA MENU>** to delete the selected character.

STEP 7: When the setting is completed, move the cursor to **<SAVE>** and press **<CAMERA MENU>** to save.

After completing title setting, go back to the **MAIN PAGE 2** to carry on setup of Preset points.

| MAIN PAGE 2 | |
|---------------|-------|
| ID DISPLAY | ON |
| TITLE DISPLAY | OFF |
| TITLE SETTING | 01 |
| PRESET | ENTER |
| SEQUENCE | ENTER |
| AUTOPAN | ENTER |
| CRUISE | ENTER |
| HOME SETTING | ENTER |

3.3.12 PRESET

- **PRESET SET**

Totally 256 preset points can be set. Follow the steps below when in the preset setting menu.

STEP 1: Press the right/left key on the keyboard to select a number (001 represents preset point 1, 002 represents preset point 2, etc.)

STEP 2: Press the <**CAMERA MENU**> key (ENTER) on the keyboard, and then move the Dome Camera to a targeted shooting area/point.

STEP 3: Press the <**CAMERA MENU**> key again to save the defined preset point.

Once completing setup of a preset point, users could move the cursor to the next item to run the preset point.

- **PRESET RUN**

Press the <**CAMERA MENU**> key (ENTER), and the camera will go to the appointed point. To run other defined preset point, simply press the right/left key on the keyboard, select the preset point that you want to go, and press the <**CAMERA MENU**> key (ENTER) again.

- **EXIT**

Exit the PRESET menu and go back to the **MAIN PAGE 2** to carry on setup of Sequence.

| MAIN PAGE 2 | |
|---------------|-------|
| ID DISPLAY | ON |
| TITLE DISPLAY | OFF |
| TITLE SETTING | 01 |
| PRESET | ENTER |
| SEQUENCE | ENTER |
| AUTOPAN | ENTER |
| CRUISE | ENTER |
| HOME SETTING | ENTER |



NOTE: Users could set preset points through a keyboard. Please refer to the control keyboard's quick guide for further information.

3.3.13 SEQUENCE

The function executes pre-positioning of the pan, tilt, zoom and focus features in a certain sequence for a camera. Before setting this function, users must pre-define at least two preset points.

| SEQUENCE | |
|-----------------|-------|
| SEQUENCE LINE | 1 |
| SEQUENCE POINT | 01 |
| PRESET POSITION | 001 |
| SPEED | 01 |
| DWELL TIME | 001 |
| RUN SEQUENCE | ENTER |
| EXIT | YES |

- **SEQUENCE LINE**

There are eight sets of sequence lines built in the Dome Camera. Using LEFT/RIGHT direction keys to select a line first and then set its sequence points.

- **SEQUENCE POINT**

Up to 64 points can be setup for each Sequence line. The Sequence Points represent order of the preset points that the Dome Camera will automatically run. The following setup items, including PRESET POSITION, SPEED and DWELL TIME, will influence how the camera runs through each sequence point.

- **PRESET POSITION**

Users can assign a specific preset position to the selected Sequence Point with this item. Options include "1~256" and "END." END is used for the Sequence Point following the last Sequence Point when the amount of sequence points (see the previous section) is less than 64 points.



NOTE: If not all 64 points are used, please set the point following the last Sequence Point as "END" (PRESET POSITION) so that the sequence line can work properly. For example, if a user intends to set a Sequence Line with 5 sequence points. It is required to set the PRESET POSITION of Sequence Point 06 as "END."

- **SPEED**

Users can set the pan/tilt speed of the Dome Camera from one sequence point to the next one, and the range of setup speed is from 1 to 15. Within the range, PAN speed varies from 10 ~ 400 (degree/sec.), and TILT speed varies from 8 ~ 400(degree/sec.).

- **DWELL TIME**

The DWELL TIME is the duration time that the Dome Camera will stay at a sequence point, and the range is from <0> to <127> seconds. The Dome Camera will go to the next sequence point when the DWELL TIME expires. If the setting is <0>, the Dome Camera will stay at this sequence point for less than 1 second and then shift to the next point

- **RUN SEQUENCE**

Users can command the Dome Camera to run the selected sequence line manually. Press the <CAMERA MENU> key (ENTER) to execute a sequence line.

- **EXIT**

Select the item to exit the SEQUENCE menu; go back to the **MAIN PAGE 2** to carry on setup of Auto-pan.

| MAIN PAGE 2 | |
|---------------|-------|
| ID DISPLAY | ON |
| TITLE DISPLAY | OFF |
| TITLE SETTING | 01 |
| PRESET | ENTER |
| SEQUENCE | ENTER |
| AUTOPAN | ENTER |
| CRUISE | ENTER |
| HOME SETTING | ENTER |



NOTE: Users could execute the sequence function through a keyboard. Please refer to the control keyboard's quick guide for further information.

3.3.14 AUTOPAN

Auto-pan means motion of scanning an area horizontally so that the Dome Camera can catch horizontal view. The parameters are listed as follows.

| AUTOPAN | |
|--------------|---------|
| AUTOPAN LINE | 1 |
| START POINT | TO FIND |
| END POINT | TO FIND |
| DIRECTION | RIGHT |
| SPEED | 01 |
| RUN AUTOPAN | ENTER |
| EXIT | YES |

- **AUTOPAN LINE**

There are four sets of auto-pan line built in a Dome Camera. Users can choose a line to execute using LEFT/RIGHT direction keys. In addition, users are able to command the Dome Camera to do endless panning by setting the start point the same as the end point.

- **START POINT**

Follow the description below to set the start position of the AUTOPAN path.

1. Move the cursor to <START POINT> and press <ENTER> while the item, <TO FIND>, is flashing. Then the item will turn <TO SAVE> automatically.
2. Move the Dome Camera to a desired position and press <ENTER> to save the position as the start point; the cursor will move to <END POINT> automatically. Ensure setting the end point to complete auto-pan setting.



NOTE: The tilt and zoom values of the start point will be recorded and **fixed** for the selected Auto-pan line.

- **END POINT**

Users are able to set the end point after the start point is defined. Pan the Dome Camera to another position and press <ENTER> to save the position as the end point.

- **DIRECTION**

The item is for setting the AUTOPAN direction of the Dome Camera. The Dome Camera will start to pan clockwise from the start point to the end point if your selection is <RIGHT>, and then return to the start point. The camera will start to pan anti-clockwise from the start point to the end point if your selection is <LEFT>. Refer to the diagram below.

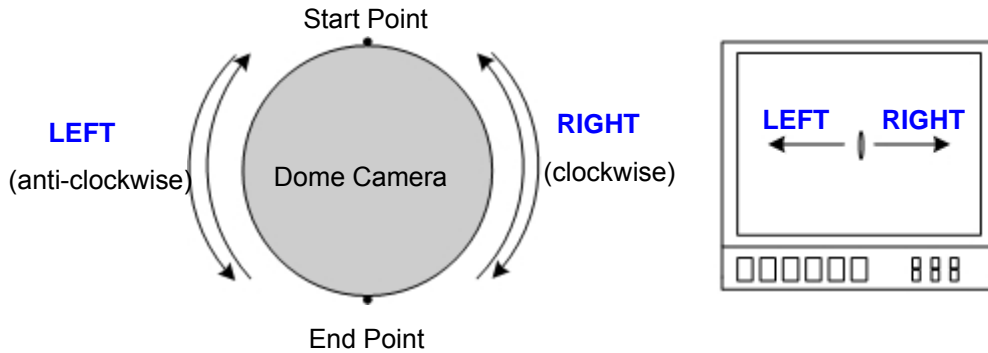

- **SPEED**

The item is for defining the Dome Camera rotation speed while running Auto-pan. The speed is adjustable from 1 to 4 (10 ~ 45 degree/sec.).

- **RUN AUTOPAN**

After all setting related to auto-pan are completed, select this item to execute the Auto-pan function. Press the <**CAMERA MENU**> key (ENTER) to run an Auto-pan path.

- **EXIT**

Exit the AUTOPAN setup menu; go back to the **MAIN PAGE 2** to carry on setup of Cruise.

| MAIN PAGE 2 | |
|---------------|-------|
| ID DISPLAY | ON |
| TITLE DISPLAY | OFF |
| TITLE SETTING | 01 |
| PRESET | ENTER |
| SEQUENCE | ENTER |
| AUTOPAN | ENTER |
| CRUISE | ENTER |
| HOME SETTING | ENTER |



NOTE: Users could execute the auto-pan function through a keyboard. Please refer to the control keyboard's quick guide for further information.

3.3.15 CRUISE

CRUISE is a route formed with manual operation, through adjusting pan, tilt position and zoom parameters, which can be stored and recalled to execute repeatedly.

| CRUISE | |
|--------------|-------|
| CRUISE LINE | 1 |
| RECORD START | ENTER |
| RECORD END | ENTER |
| RUN CRUISE | ENTER |
| EXIT | YES |

- **CRUISE LINE**

Up to eight sets of Cruise routes can be created for one camera. Using LEFT/RIGHT direction keys to select a line first and then follow the steps below to start recording the Cruise route.

- **RECORD START**

Follow the description below to record the CRUISE path.

1. Rotate the Dome Camera to a desired view area (for some protocols, users may need to do it before entering the OSD), and press <ENTER> to build the cruise path using the joystick on the control device. The percentage of the memory buffer used will be displayed on the screen.
2. Pan, tilt and zoom the Dome Camera to form a path.



NOTE: Beware of the memory size when building a cruise path. Once the buffer percentage reaches 100%, recording of the path will stop.

- **RECORD END**

The cursor will be moved to RECORD END while building the Cruise route; when the setting is completed, press <ENTER> to save the route.

- **RUN CRUISE**

After cruise setting is completed, press the <CAMERA MENU> key (ENTER) to run the defined Cruise path.

- **EXIT**

Exit the CRUISE setup menu; go back to the **MAIN PAGE 2** to carry on setup of Home Setting.

| MAIN PAGE 2 | |
|---------------|-------|
| ID DISPLAY | ON |
| TITLE DISPLAY | OFF |
| TITLE SETTING | 01 |
| PRESET | ENTER |
| SEQUENCE | ENTER |
| AUTOPAN | ENTER |
| CRUISE | ENTER |
| HOME SETTING | ENTER |



NOTE: Users could execute the cruise function through a keyboard. Please refer to the control keyboard's quick guide for further information.

3.3.16 HOME SETTING

Users are able to set an operation mode to ensure constant monitoring. If the Dome Camera idles for a period of time, the selected function will be activated automatically; this is the HOME function. The HOME function allows constant and accurate monitoring to avoid the Dome Camera idling or missing events.

| HOME SETTING | |
|---------------|---------|
| HOME FUNCTION | OFF |
| SELECT MODE | PRESET |
| PRESET POINT | 001 |
| RETURN TIME | 001MIN. |
| GO | ENTER |
| EXIT | YES |

- **HOME FUNCTION**

The item is used to enable or disable the HOME function. Use the left/right direction keys of the control keyboard to change the setting.

- **SELECT MODE**

Select one of the modes that the Dome Camera should execute when the HOME function is enabled and the RETURN TIME expires. The options include <AUTOPAN>, <SEQUENCE>, <CRUISE> and <PRESET>. Use the left/right direction keys of the control keyboard to change the setting, and the items below will change in cooperating with your selection.

- **PRESET POINT**

Select a preset point where the Dome Camera should go after the Return Time function, which will be mentioned later, is activated. The preset point(s) should be set prior either in the PRESET setup menu or through the keyboard.

SEQUENCE LINE

Select a sequence line that the Dome Camera should execute after the Return Time function is activated. The sequence line(s) should be defined prior either in the SEQUENCE setup menu or through the keyboard.

AUTOPAN LINE

Select an auto-pan line that the Dome Camera should execute after the Return Time function is activated. The auto-pan line(s) should be defined prior either in the AUTOPAN setup menu or through the keyboard.

CRUISE LINE

Select a cruise line that the Dome Camera should execute after the Return Time function is activated. The cruise line(s) should be defined prior either in the CRUISE setup menu or through the keyboard.

- **RETURN TIME**

The Dome Camera starts to count down RETURN TIME when the Dome Camera idles, and then execute the SELECT MODE function when the return time is up. The RETURN TIME ranges from 1 to 128 minutes.

- **GO**

If HOME function is enabled, users are allowed to execute HOME function by selecting this item.

- **EXIT**

Exit the HOME SETTING menu. Then go to the **MAIN PAGE 3** to carry on other setups.



NOTE: If use R model, please skip the following section and go to [3.3.18 ALARM SETTING](#) to continue setup of alarm related setting.

G/V/T/L/M Model:

| MAIN PAGE 3 | |
|---------------|-------|
| IR FUNCTION | AUTO |
| ALARM SETTING | ENTER |
| ALARM DETECT | OFF |
| WDR FUNCTION | OFF |
| PRIVACY MASK | ENTER |
| TIME SETTING | ENTER |
| SCHEDULE | ENTER |
| EXIT OSD | YES |

R Model:

| MAIN PAGE 3 | |
|---------------|-------|
| IR FUNCTION | NONE |
| ALARM SETTING | ENTER |
| ALARM DETECT | NONE |
| WDR FUNCTION | NONE |
| PRIVACY MASK | NONE |
| TIME SETTING | ENTER |
| SCHEDULE | ENTER |
| EXIT OSD | YES |

S1/S2 Model:

| MAIN PAGE 3 | |
|---------------|-------|
| IR FUNCTION | AUTO |
| ALARM SETTING | ENTER |
| ALARM DETECT | NONE |
| WDR FUNCTION | NONE |
| PRIVACY MASK | ENTER |
| TIME SETTING | ENTER |
| SCHEDULE | ENTER |
| EXIT OSD | YES |

3.3.17 IR FUNCTION (Removable IR Cut Filter)

With the IR cut filter, the Dome Camera can still catch clear image at night time or in low light conditions. During day time, the IR cut filter will be on to block the infrared light for clear image; during night time, the IR cut filter will be removed to catch infrared light, and the displayed images will become black and white. Moreover, in L and M models, users are able to view color images when the IR function is activated. Refer to the description below to operate the IR function.

G/V/T Model:

- **AUTO**

The Internal circuit will automatically decide the occasion to remove the IR cut filter according to the value of light condition calculated by the internal light algorithm.

- **MANUAL**

IR MANUAL ON

Select the item to remove the IR cut filter; the camera will be in B/W (Night) mode.

IR MANUAL OFF

Select the item to attach the IR cut filter; the camera will be in Color (Day) mode.

L/M Model:

Select one of the IR modes below through the right key on the control keyboard. Press the <**CAMERA MENU**> key (ENTER) on the selected mode to enter its submenu, which will be described later.

- **AUTO**

The Internal circuit will automatically decide the occasion to remove the IR cut filter according to the image brightness level.



NOTE: When IR function is in AUTO mode, AE will automatically become AUTO mode. Additionally, if AE is set as Shutter, Iris and AGC priority mode, the IR AUTO function will be invalid. To resume IR AUTO function in this case, users can 1) adjust AE to AUTO mode; 2) adjust IR function to ON/OFF mode, and then switch back to AUTO mode.

- **ON**

Select the item to remove the IR cut filter.

- **OFF**

Select the item to disable IR function.



NOTE: When Alarm Detect function (see section [3.3.19 ALARM DETECT](#)) is turned on, IR function will automatically switch to ON/OFF mode.

Sub-menu of IR Function:

| | |
|-------------|-------|
| IR FUNCTION | |
| THRESHOLD | LOW |
| IR COLOR | COLOR |
| EXIT+SAVE | YES |

THRESHOLD

The Dome Camera will remove the filter immediately when the threshold value is reached. The threshold options are <LOW>, <MID> and <HI>. <LOW> threshold indicates a higher sensitivity and can improve reliability of lens that it is easier to switch to Day mode and relatively difficult to change into Night mode; while <HI> indicates that it is easier to switch to Night mode and difficult to change into Day mode.

IR COLOR

When the IR function is removed, the video output can be programmed as color or B/W (black and white). The color here refers to simulate color, not real color. This function is only applicable in IR ON mode.

Exit

Exit the IR function menu and go back to the **MAIN PAGE 3** to carry on setup of alarm setting.

| MAIN PAGE 3 | |
|---------------|-------|
| IR FUNCTION | AUTO |
| ALARM SETTING | ENTER |
| ALARM DETECT | OFF |
| WDR FUNCTION | OFF |
| PRIVACY MASK | ENTER |
| TIME SETTING | ENTER |
| SCHEDULE | ENTER |
| EXIT OSD | YES |

S1/S2 Model

- **AUTO**

The Internal circuit will automatically decide the occasion to remove the IR cut filter according to the value of light condition calculated by the internal light algorithm. The options include <LOW>, <MID> and <HI>. <LOW> indicates a higher sensitivity and can improve reliability of lens so that it is easier to switch to Day mode and relatively difficult to change into Night mode; while <HI> indicates that it is easier to switch to Night mode and difficult to change into Day mode.

- **MANUAL**

IR MANUAL ON

Select the item to remove the IR cut filter; the camera will be in B/W (Night) mode.

IR MANUAL OFF

Select the item to attach the IR cut filter; the camera will be in Color (Day) mode to disable the IR function.

3.3.18 ALARM SETTING

The Dome Camera provides eight alarm inputs and one alarm output (N.O. or N.C) to connect alarm devices. With this function, the Dome Camera can cooperate with alarm system to catch events' images. For wiring, please refer to the installation guide and/or qualified service personnel. Adjustable alarm parameters are listed below.

| ALARM SETTING | |
|---------------|--------|
| ALARM PIN | 1 |
| ALARM SWITCH | OFF |
| ALARM TYPE | N.C. |
| ALARM ACTION | PRESET |
| PRESET POINT | 001 |
| DWELL TIME | ALWAYS |
| EXIT | YES |

- **ALARM PIN**

The Dome Camera provides 8 alarm inputs and 1 output (N.O. or N.C.). Select an alarm connector which you want to set its alarm-related parameters with this item, and then set its alarm-related parameters in the Alarm Setting menu. For alarm pin definitions, please refer to [2.6 22-Pin Connector Definition](#) or the installation guide.



NOTE: If two or more alarm pins are triggered at the same time, smaller alarm pin number will have higher priority of being handled. For example, if Alarm-1 and Alarm-3 are triggered simultaneously, only Alarm-1 will actually be handled.

- **ALARM SWITCH**

The item is used to enable or disable the selected alarm pin function. Use the left/right direction keys on the control keyboard to change the setting.

- **ALARM TYPE**

There are two kinds of alarm types: Normal Open and Normal Close, which are illustrated as below. Select an alarm type that corresponds with the alarm application.

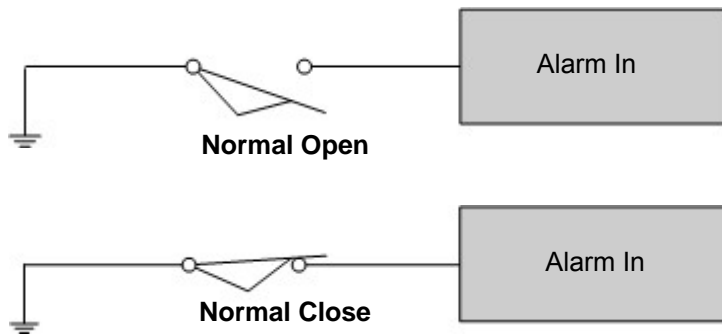

- **ALARM ACTION**

The alarm actions include PRESET, SEQUENCE, AUTOPAN and CRUISE functions. Select one of these modes so that certain action will be executed when an alarm is triggered. Use the right direction key of the control keyboard to select a particular action mode, and the items listed below will change in accordance with your selected alarm action. Additionally, when an alarm is triggered, there will be a flash warning notice: ALARM displayed in the upper right corner of the screen.

- **PRESET POINT**

Select a preset point where the Dome Camera should go when an alarm pin is triggered. The preset point(s) should be set prior either in the PRESET setup menu or through the keyboard.

SEQUENCE LINE

Select a sequence line that the Dome Camera should execute when an alarm pin is triggered. The sequence line(s) should be defined prior either in the SEQUENCE setup menu or through the keyboard.

AUTOPAN LINE

Select an auto-pan line that the Dome Camera should execute when an alarm pin is triggered. The auto-pan line(s) should be defined prior either in the AUTOPAN setup menu or through the keyboard.

CRUISE LINE

Select a cruise line that the Dome Camera should execute when an alarm pin is triggered. The cruise line(s) should be defined prior either in the CRUISE setup menu or through the keyboard.

- **DWELL TIME**

The DWELL TIME is duration of executing an alarm action. If the PRESET mode is selected, the Dome Camera will go to the selected preset position and stay there for a user-defined period of time (1~127seconds/Always) when alarm takes place. If other modes (SEQUENCE/AUTOPAN/ CRUISE) have been selected, the camera will keep executing the selected mode (DWELL TIME: ALWAYS) until alarm condition is released or users rotate the joystick to change the status of the Dome Camera.



NOTE: The dwell time is only adjustable when selecting **Preset** as the alarm action. When the dwell time is up, the Dome Camera will go back to its trigger position and recheck alarm pin status.

- **EXIT**

Exit the ALARM SETTING menu and go back to the **MAIN PAGE 3** to carry on setup of Alarm Detect (G/V/T/L/M models only).

G/V/T/L/M Model:

| MAIN PAGE 3 | |
|---------------|-------|
| IR FUNCTION | AUTO |
| ALARM SETTING | ENTER |
| ALARM DETECT | OFF |
| WDR FUNCTION | OFF |
| PRIVACY MASK | ENTER |
| TIME SETTING | ENTER |
| SCHEDULE | ENTER |
| EXIT OSD | YES |

If use S1/S2 models, after exiting the ALARM SETTING menu, go back to the **MAIN PAGE 3** to carry on setup of Privacy Mask function. Thus please skip the next section and go to [3.3.21 PRIVACY MASK](#) to continue setup of Privacy Mask function.

S1/S2 Model:

| MAIN PAGE 3 | |
|---------------|-------|
| IR FUNCTION | AUTO |
| ALARM SETTING | ENTER |
| ALARM DETECT | NONE |
| WDR FUNCTION | NONE |
| PRIVACY MASK | ENTER |
| TIME SETTING | ENTER |
| SCHEDULE | ENTER |
| EXIT OSD | YES |

If use the R model, please skip the next three sections and go to [3.3.22 TIME SETTING](#).

R Model:

| MAIN PAGE 3 | |
|---------------|-------|
| IR FUNCTION | NONE |
| ALARM SETTING | ENTER |
| ALARM DETECT | NONE |
| WDR FUNCTION | NONE |
| PRIVACY MASK | NONE |
| TIME SETTING | ENTER |
| SCHEDULE | ENTER |
| EXIT OSD | YES |

3.3.19 LARM DETECT (G/V/T/L/M Model)

When the alarm detect function is activated, the camera will detect movement within a monitoring area and then send an alarm signal automatically. There will be a flash warning notice: MOTION displayed in the upper left corner of the screen.

G/V/T Model:

| ALARM DETECT | |
|---------------|------|
| DETEC SWITCH | OFF |
| DETEC MODE | NONE |
| BLOCK MODE | NONE |
| FRAME SET | NONE |
| FRAME DISABLE | NONE |
| THRESHOLD | NONE |
| EXITD | YES |

- **DETECT SWITCH**
The item is used to enable or disable the ALARM DETECT function.
- **DETECT MODE**
Four alarm detect modes are provided for different application.

INT FOCUS (Internal Focus)

The alarm will be triggered if the internal focus changes; if the focus returns to the original position, the alarm will stop.

FIX FOCUS

If focus movement is detected, the alarm will be triggered, and the alarm stops when focus returns to the original position. If the detected focus movement keeps changing for more than four seconds, the new focus

position will be memorized as the reference, and the alarm will stop.



NOTE: The INT FOCUS and FIX FOCUS detect modes will be activated only with the Auto Focus mode.

INT AE (Internal AE)

When Auto Exposure (AE) movement is detected, the alarm will be triggered; if the Exposure Level returns to the original level, the alarm will stop.

FIX AE

The alarm will be triggered if the Exposure value changes; if the adjusted AE value retains for four seconds, the value will be saved as the reference, and the alarm will stop.

MOTION

Motion Detection function allow detecting suspicious motion and triggering alarms when motion volume in the detected area reaches/exceeds the determined sensitivity threshold value. The main menu is shown below:

| ALARM DETECT | |
|---------------|--------|
| DETEC SWITCH | OFF |
| DETEC MODE | MOTION |
| BLOCK MODE | ON |
| FRAME SET | 01 |
| FRAME DISABLE | 01 |
| THRESHOLD | 016 |
| EXITD | YES |

- **BLOCK MODE**

In Motion Detect Mode, users can set Block Mode as “ON” or “OFF”. When BLOCK MODE is turned on, if there are any variations (e.g. caused by intrusion) in the sections of the monitoring image, the affected parts will be highlighted dynamically.

- **FRAME SET**

In a monitored field, users can define specific areas as motion detection target zones. Please refer to the instructions as follows to configure parameters for each motion detection zone so-called “Frame.” When motion is detected within a defined frame, a flash warning notice: MOTION, will display in the upper left corner of the screen.

Total four frames can be set. Select a frame using the right/left keys on the keyboard, and press “ENTER” key to enter the frame’s submenu, as shown below.

| FRAME SET 1 | |
|--------------|---------|
| LEFT LIMIT | L/R |
| TOP LIMIT | D/U |
| H SIZE | 000 |
| V SIZE | 000 |
| MODE | PRESET |
| PRESET POINT | 001 |
| DWELL TIME | 001 SEC |
| EXIT | YES |

LEFT LIMIT

Move the frame right/left using the right/left keys on the keyboard.

TOP LIMIT

Shift the frame up/down using the right/left keys on the keyboard.

H/V SIZE

Adjust the frame size via changing H/V size value using the right/left keys on the keyboard.

MODE

Assign a trigger action for a motion detection frame. Options include PRESET, SEQUENCE, AUTOPAN and CRUISE. When motion is detected within a frame, the Dome Camera will execute the specific trigger action.

DWELL TIME

The DWELL TIME is duration of executing a trigger action. If select the PRESET mode, when motion is detected, the Dome Camera will go to the selected Preset position and stay there for a user-defined period of time (1~127 seconds/Always). If select other modes (SEQUENCE/AUTOPAN /CRUISE), the Dome Camera will keep executing the selected mode (DWELL TIME: ALWAYS) until it is interrupted by commands sent from a connected control device.

EXIT

Exit the FRAME setting page and go back to ALARM DETECT main page.

- **FRAME DISABLE**

Select a frame to be canceled, and press “ENTER.” The selected frame will then be removed from the monitored field.

- **THRESHOLD**

The Threshold range is adjustable from 1~255. The smaller the value, the more sensitive it is; i.e. 1: highest sensitivity; 255: lowest sensitivity.

- **EXIT**

Exit the ALARM DETECT menu and go back to the **MAIN PAGE 3** to carry on setup of WDR function (see [3.3.20 WDR FUNCTION](#)).

| MAIN PAGE 3 | |
|---------------|-------|
| IR FUNCTION | AUTO |
| ALARM SETTING | ENTER |
| ALARM DETECT | OFF |
| WDR FUNCTION | OFF |
| PRIVACY MASK | ENTER |
| TIME SETTING | ENTER |
| SCHEDULE | ENTER |
| EXIT OSD | YES |

L/M Model:

- **ON**

The camera will automatically execute motion detection within the monitoring area.



NOTE: For L and M models, when Alarm Detect is turned on, the following functions will be affected: 1) AE becomes AUTO mode; 2) IR becomes ON/OFF mode; 3) Privacy Mask is turned OFF; 4) Digital Zoom is turned OFF; 5) No Auto Focus; 6) Digital Slow Shutter won't work. Additionally, when Alarm Detect function is on, if the Dome Camera is controlled to execute motions (ex. Tilt and Pan) or functions (Preset, Sequence and Auto-pan), Alarm Detect will be disabled temporarily during that time. The function will be resumed in 3 to 5 seconds after all motions stop. Nevertheless, if the dwell time between preset positions of a Sequence line is set more than 5 seconds, Alarm Detect function will be activated after 5 seconds and will be turned off temporarily again when the camera starts to go to the next preset position.

- **OFF**

The item is used to disable Alarm Detect function.

3.3.20 WDR FUNCTION (G/V/T/L/M Model)

The Wide Dynamic Range (WDR) function is especially effective in solving indoor and outdoor contrast issues to enhance better image quality and video display. It enables the Dome Camera to catch detailed data from the dark part (Indoor) without any saturation from the bright part (Outdoor).

G/V/T Model:

- **ON**
Activate the WDR function by selecting this option. In this mode, the Dome Camera will operate the WDR function automatically.

- **OFF**
Deactivate the WDR function.

L/M Model:

- **AUTO**
In this mode, the Dome Camera will operate the WDR function automatically.

- **ON**
Under the item, users can define three parameters' value: RATIO LEVEL (000 ~ 128), SHUTTER SPEED (000 ~ 128) and IRIS OFFSET (000 ~ 128), as shown in the following column.

| WDR MODE | |
|---------------|-----|
| RATIO LEVEL | 000 |
| SHUTTER SPEED | 000 |
| IRIS OFFSET | 000 |
| EXIT | YES |



NOTE: The parameter effects set here will be limited if Image Inverse is turned on.

- **OFF**
Select this option to disable the WDR function.

Exit the WDR FUNCTION menu and go back to the **MAIN PAGE 3** to carry on setup of Privacy Mask.

G/V/T/L/M Model:

| MAIN PAGE 3 | |
|---------------|-------|
| IR FUNCTION | AUTO |
| ALARM SETTING | ENTER |
| ALARM DETECT | OFF |
| WDR FUNCTION | OFF |
| PRIVACY MASK | ENTER |
| TIME SETTING | ENTER |
| SCHEDULE | ENTER |
| EXIT OSD | YES |



NOTE: For L and M models, when WDR function is at AUTO or ON mode, the following functions will be affected: 1) Backlight Compensation will be turned OFF; 2) Image Stabilizer will be turned OFF; 3) AE becomes AUTO mode; 4) Digital Slow Shutter has no function.

3.3.21 PRIVACY MASK (Excluding R Model)

The Privacy Mask function aims to avoid any intrusive monitoring. Users can adjust the camera view position using the joystick, and adjust the mask size and area via the direction keys on the control keyboard. When setting a mask, it is suggested to set it at least *twice bigger* (height and width) than the masked object. The Dome Camera will assume the center of the selected view as a starting point, and the joystick will be locked as users enter the SET MASK menu (mentioned later). Refer to the following description for setting Privacy Masks.



NOTE: The Image Flip function and the Image Inverse function will be disabled automatically while the Privacy Mask function is enabled.

G/V/T/S1/S2 Model:

For these models, the available area for setting a privacy mask is restricted within tilt angle 70 degrees. Maximum 8 masks can be displayed in one scene. All the settings are described as the following:

| PRIVACY MASK MENU | |
|-------------------|-------|
| PRIVACY SWITCH | OFF |
| TRANSPARENCY | OFF |
| COLOR | BLACK |
| SET MASK | 01 |
| CLEAR MASK | 01 |
| EXIT | YES |

- **PRIVACY SWITCH**

Users can enable or disable the Privacy Mask function through this item. Set this item to <ON> before configuring mask zones.

- **TRANSPARENCY**

The color of privacy mask can be set as transparent. Select <ON> to display transparent masks.

- **COLOR**

The color of privacy mask can be set through this item. The available colors are black, HI/LO gray (G/V/T models only), white, red, green, blue, cyan, yellow and magenta.

- **SET MASK**

Use the control device to move the Dome Camera to the area where you want to set a mask. Press <ENTER> to enter the SET MASK menu. The Dome Camera will memorize the present position as a privacy mask position. Up to 24 masks can be set for F/U model.

| MASK01 MENU | |
|-------------|-----|
| H CENTER | L/R |
| V CENTER | D/U |
| H SIZE | 000 |
| V SIZE | 000 |
| EXIT+SAVE | YES |

H CENTER

The original horizontal center of a mask zone is the center of a screen; it is able to move a mask zone to the other position by adjusting the horizontal value with the LEFT/RIGHT keys on the keyboard. The camera will pan right or left according to user's control.

V CENTER

The original vertical center of a mask zone is the center of a screen; it is able to move a mask zone to the other position by adjusting the vertical value with the LEFT/RIGHT keys on the keyboard. The camera will tilt up or down according to user's control.

H SIZE (00~80)

Users can adjust the horizontal size of a privacy mask through this item. Set the H and V size to 0 can also delete the selected mask.

V SIZE (00~60)

Users can adjust the vertical size of a privacy mask through this item. Set the H and V size to 0 can also delete the selected mask.

- **CLEAR MASK**

Users can delete a preset mask zone with this item. Please follow the steps listed below.

1. Select the mask zone that will be erased (e.g. 01).
2. Press <ENTER> to confirm the selection.

- **EXIT**

Exit the PRIVACY MASK menu and go back to the **MAIN PAGE 3** to carry on setup of time related setting.

G/V/T Model:

| MAIN PAGE 3 | |
|---------------|-------|
| IR FUNCTION | AUTO |
| ALARM SETTING | ENTER |
| ALARM DETECT | OFF |
| WDR FUNCTION | OFF |
| PRIVACY MASK | ENTER |
| TIME SETTING | ENTER |
| SCHEDULE | ENTER |
| EXIT OSD | YES |

S1/S2 Model:

| MAIN PAGE 3 | |
|---------------|-------|
| IR FUNCTION | AUTO |
| ALARM SETTING | ENTER |
| ALARM DETECT | NONE |
| WDR FUNCTION | NONE |
| PRIVACY MASK | ENTER |
| TIME SETTING | ENTER |
| SCHEDULE | ENTER |
| EXIT OSD | YES |

L/M Model:

For L and M models, when Privacy Mask function is enabled, Alarm Detect function will automatically be disabled.

| PRIVACY | |
|----------------|-------|
| PRIVACY SWITCH | OFF |
| SHADE | BLACK |
| SET MASK | 01 |
| CLEAR MASK | 01 |
| MASK DISPLAY | FIRST |
| EXIT | YES |

- **PRIVACY SWITCH**

The item is used to enable or disable the masking function. Set this item to <ON> before configuring mask zones.

- **SHADE**

The color of a privacy mask can be selected through this item. The available colors are black, gray and white.

- **SET MASK**

After pressing <ENTER> to enter the sub-menu of SET MASK, the Dome Camera will memorize the present position as a privacy mask position; up to 8 masks can be set. The model restricts the mask zones to be set too close with each other.



NOTE: For L and M models, the available area for setting a privacy mask is restricted within tilt angle 45°, and two mask zones are allowed to set in a view area.

| MASK01 MENU | |
|-------------|-----|
| H CENTER | 000 |
| V CENTER | 000 |
| H SIZE | 000 |
| V SIZE | 000 |
| EXIT+SAVE | YES |

H CENTER (000~255)

The original center of a mask zone is the center of a screen. Users can move the center of a mask zone to another position by pressing the LEFT/RIGHT keys on the keyboard to adjust the value.

V CENTER (000~255)

The original center of mask zone is the center of screen. User can move the center of mask zone to another position by pressing the LEFT/RIGHT keys on the keyboard to adjust the value.

H SIZE (000~127)

Users can adjust the horizontal size of a privacy mask through this item. Set the H and V size to 0 can also delete the selected mask.

V SIZE (000~127)

User can adjust the vertical size of a privacy mask through this item. Set the H and V size to 0 can also delete the selected mask.



NOTE: A mask's size should be limited within the screen, whatever the optical zoom is.

- **CLEAR MASK**

Users can delete a preset mask zone with this item. Please follow the steps listed below.

1. Select the mask zone that will be erased (e.g. 01).

2. Press <ENTER> to confirm the selection. Consequently, the screen will display the instructions to reset after the mask is cleared.
3. Select <RESET> under the CLEAR MASK item and press <ENTER> to proceed with resetting.

- **MASK DISPLAY**

This item is used to set the time to display a privacy mask.

FIRST

If this mode is selected, the camera will detect the mask zone at the next preset position and display the mask in advance, and then pan the Dome Camera to the preset point.

LAST

If this mode is selected, the camera will move to the preset point first, and then display the mask zone.

- **EXIT**

Exit the PRIVACY MASK menu and go back to the **MAIN PAGE 3** to carry on setup of time related setting.

L/M Model:

| MAIN PAGE 3 | |
|---------------|-------|
| IR FUNCTION | AUTO |
| ALARM SETTING | ENTER |
| ALARM DETECT | OFF |
| WDR FUNCTION | OFF |
| PRIVACY MASK | ENTER |
| TIME SETTING | ENTER |
| SCHEDULE | ENTER |
| EXIT OSD | YES |

3.3.22 TIME SETTING

The time setting function is used to set the TIME related parameters of the Dome Camera. Each item in the menu is listed as follows.

| TIME SETTING | |
|--------------|-----|
| TIME DISPLAY | OFF |
| SET YEAR | 00 |
| SET MONTH | 01 |
| SET DAY | 00 |
| SET HOUR | 00 |
| SET MINUTE | 00 |
| EXIT+SAVE | YES |

- **TIME DISPLAY**

Select <ON> to display time information on the screen or <OFF> not to display.

- **YEAR / MONTH / DAY**

The items are for setting up the system date.

- **HOUR / MINUTE**

The items are for setting up the system time.

- **EXIT+SAVE**

Exit the TIME SETTING menu and go back to the **MAIN PAGE 3** to carry on setup of schedule.

G/V/T/L/M Model:

| MAIN PAGE 3 | |
|---------------|-------|
| IR FUNCTION | AUTO |
| ALARM SETTING | ENTER |
| ALARM DETECT | OFF |
| WDR FUNCTION | OFF |
| PRIVACY MASK | ENTER |
| TIME SETTING | ENTER |
| SCHEDULE | ENTER |
| EXIT OSD | YES |

R Model:

| MAIN PAGE 3 | |
|---------------|-------|
| IR FUNCTION | NONE |
| ALARM SETTING | ENTER |
| ALARM DETECT | NONE |
| WDR FUNCTION | NONE |
| PRIVACY MASK | NONE |
| TIME SETTING | ENTER |
| SCHEDULE | ENTER |
| EXIT OSD | YES |

S1/S2 Model:

| MAIN PAGE 3 | |
|---------------|-------|
| IR FUNCTION | AUTO |
| ALARM SETTING | ENTER |
| ALARM DETECT | NONE |
| WDR FUNCTION | NONE |
| PRIVACY MASK | ENTER |
| TIME SETTING | ENTER |
| SCHEDULE | ENTER |
| EXIT OSD | YES |

3.3.23 SCHEDULE

The schedule function enables users to program a preset point or function (Sequence/Auto-pan/Cruise) automatically to perform in a specific period of time.

| SCHEDULE | |
|----------------|--------|
| SWITCH | OFF |
| POINT | 00 |
| HOUR | 00 |
| MINUTE | 00 |
| MODE | PRESET |
| PRESET POINT | 001 |
| SCHEDULE RESET | YES |
| EXIT | YFS |

- SWITCH**
 Select <ON> to enable or <OFF> to disable the schedule function.
- POINT**
 Users are allowed to arrange 64 sets of schedule point, i.e. each set of schedule point can be assigned one kind of schedule modes.
- HOUR / MINUTE**
 The items are for setting up the time to execute each schedule point.
- MODE**
 This is for setting the schedule function of the selected schedule point; the options are listed as follows.
 - NONE**
 No action will be executed for the schedule if select the item.

PRESET

Users can select the PRESET mode as an action carried out in a schedule point.

SEQUENCE

Users can select the SEQUENCE mode as an action carried out in a schedule point.

AUTOPAN

Users can select the AUTOPAN mode as an action carried out in a schedule point.

CRUISE

Users can select the CRUISE mode as an action carried out in a schedule point.

IR FUNC. (IR Function)

If the IR function mode is selected, the AUTO IR FUNCTION will be activated for a schedule point.

- **SCHEDULE RESET**

Users can reset the whole schedule with the item.

- **EXIT**

Exit the SCHEDULE menu and go back to the **MAIN PAGE 3**.

3.3.24 EXIT OSD

To exit the OSD setup menu, users can either select this item on the bottom of **MAIN PAGE 3** or press the ESC key on the control keyboard.

Appendix A: Technical Specification

| Items | | R Model | G Model | M Model | V Model | L Model | T Model |
|-------------------------|------|--|-----------------------------|----------------------------|-----------------------------|-----------------------------|----------------------------|
| CAMERA | | | | | | | |
| CCD Sensor | | 1/4" CCD | 1/4" EXview | 1/4" CCD | 1/4" EXview | 1/4" CCD | 1/4" EXview |
| Progressive Scan | | - | - | Yes | - | Yes | - |
| Optical Zoom | | 22× | 18× | 23x | 26× | 35x | 36x |
| Digital Zoom | | 1× ~ 12× variable | | | | | |
| Effective Pixels | NTSC | 380k | | | | | |
| | PAL | 440k | | | | | |
| Horizontal Resolution | NTSC | 480 TVL | 530 TVL | 540 TVL | 530 TVL | 540 TVL | 530 TVL |
| | PAL | 480 TVL | 530 TVL | 540 TVL | 530 TVL | 540 TVL | 530 TVL |
| Scanning System | | NTSC / PAL | | | | | |
| Synchronization | | Internal / Line Lock | | | | | |
| Video Output | | 1.0 Vp-p / 75 Ω, BNC | | | | | |
| S/N Ratio | | > 50 dB (AGC Off) | | | | | |
| Minimum Illumination | | 1 lux | 0.07 lux; 0.01 lux (B/W) | 0.1 lux; 0.01 lux (B/W) | 0.09 lux; 0.01 lux (B/W) | 0.05 lux; 0.01 lux (B/W) | 0.1 lux; 0.01 lux (B/W) |
| Focal Length | | 4~88 mm | 4.1~73.8 mm | 3.6~82.8 mm | 3.5~91 mm | 3.4~119 mm | 3.4~122.4 mm |
| Focus Mode | | Auto / Manual | | | | | |
| White Balance | | Auto / Manual | | | | | |
| Iris Control | | Auto / Manual | | | | | |
| Electronic Shutter | NTSC | 1/60~1/30k sec. | 1/1~1/10k sec. | 1/2~1/30k sec. | 1/1~1/10k sec. | 1/2~1/30k sec. | 1/1~1/10k sec. |
| | PAL | 1/50~1/30k sec. | 1/1~1/10k sec. | 1/1.5~1/30k sec. | 1/1~1/10k sec. | 1/1.5~1/30k sec. | 1/1~1/10k sec. |
| AGC control | | Auto / Manual | | | | | |
| Back Light Compensation | | On / Off | | | | | |
| OPERATION | | | | | | | |
| Built-in Protocol | | DynaColor, Pelco D&P, VCL, Philips, AD-422, JVC, Kalatel, etc. | | | | | |
| Multi-Language OSD | | English, French, German, Italian, Japanese, Polish, Portuguese, Russian, Spanish, Turkish, Simplified Chinese, Traditional Chinese | | | | | |
| Pan Travel | | 360° endless | | | | | |
| Tilt Travel | | -10°~100° | -10° ~ 190° | | | | |
| Manual Speed | | 0.5° ~ 90°/s | | | | | |
| Presets | | 256 | | | | | |
| Preset Accuracy | | 0.225° | | | | | |
| Preset Speed | | 5° ~ 400°/s | | | | | |
| Sequence | | 8 | | | | | |
| Auto Pan | | 4 | | | | | |
| Cruise | | 4 | | | | | |

| Items | R Model | G Model | M Model | V Model | L Model | T Model |
|-----------------------------|---|----------------------------|----------|----------|----------|----------|
| Privacy Mask | - | 24 | 8 | 24 | 8 | 24 |
| Proportional Pan & Tilt | On / Off (Pan and tilt speed proportional to zoom ratio) | | | | | |
| Resume after Power loss | Yes | | | | | |
| Zone Title | 16 | | | | | |
| Home Function | Preset, Sequence, Auto pan, Cruise | | | | | |
| Auto Flip | Mechanical / Off | Digital / Mechanical / Off | | | | |
| Digital Slow Shutter | - | On / Off | On / Off | On / Off | On / Off | On / Off |
| Electronic Image Stabilizer | - | - | - | - | On / Off | - |
| Motion Detection | - | On / Off | On / Off | On / Off | On / Off | On / Off |
| Wide Dynamic Range | - | On / Off | On / Off | On / Off | On / Off | On / Off |
| Day/Night: IR Cut Filter | - | On / Off | On / Off | On / Off | On / Off | On / Off |
| Image Inverse | - | On / Off | On / Off | On / Off | On / Off | On / Off |
| Image Freeze | - | On / Off | On / Off | On / Off | On / Off | On / Off |
| Alarm Input | 8 | | | | | |
| Alarm Output | 1 | | | | | |
| Alarm Reaction | Preset, Sequence, Auto pan, Cruise | | | | | |
| GENERAL | | | | | | |
| Environment | Indoor / Outdoor | | | | | |
| Controller Interface | RS-485 | | | | | |
| Operating Temperature | -45°C ~ 50°C (-49°F ~ 122°F) | | | | | |
| Waterproof Standard | IP66 standard | | | | | |
| Dimension | ∅172 x 302.5 mm (6.7 x 11.9 Inches) / ∅190 x 302.5 mm (7.5x 11.9 Inches), with sunshield | | | | | |
| Weight | 2.6 kg (5.7 lbs) | | | | | |
| Power Source | AC 24V ± 10% | | | | | |
| Power Consumption | 65 W (with Heater) | | | | | |
| Regulatory | CE, FCC, RoHS | | | | | |

| Items | S1 Model | | S2 Model | |
|-------------------------|--|----------------|-------------------------|--|
| CAMERA | | | | |
| CCD Sensor | 1/4" EXview | | | |
| Progressive Scan | - | | | |
| Optical Zoom | 30× | | 36× | |
| Digital Zoom | 1~12x variable | | | |
| Effective Pixels | NTSC | 380k | | |
| | PAL | 440k | | |
| Horizontal | NTSC | 540 TVL | | |
| Resolution | PAL | 540 TVL | | |
| Scanning System | NTSC / PAL | | | |
| Synchronization | Internal / Line Lock | | | |
| Video Output | 1.0 Vp-p / 75 Ω, BNC | | | |
| S/N Ratio | > 50 dB (AGC Off) | | | |
| Minimum Illumination | 0.1 lux; 0.01 lux (B/W) | | 0.1 lux; 0.01 lux (B/W) | |
| Focal Length | 3.4 ~ 102 mm | | 3.4 ~ 120 mm | |
| Focus Mode | Auto / Manual | | | |
| White Balance | Auto / Manual | | | |
| Iris Control | Auto / Manual | | | |
| Electronic Shutter | NTSC | 1/1~1/10k sec. | | |
| | PAL | 1/1~1/10k sec. | | |
| AGC control | Auto / Manual | | | |
| Back Light Compensation | On / Off | | | |
| OPERATION | | | | |
| Built-in Protocol | DynaColor, Pelco D&P, VCL, Philips, AD-422, JVC, Kalatel, etc. | | | |
| Multi-Language OSD | English, French, German, Italian, Japanese, Polish, Portuguese, Russian, Spanish, Turkish, Simplified Chinese, Traditional Chinese | | | |
| Pan Travel | 360° endless | | | |
| Tilt Travel | -10° ~ 190° | | | |
| Manual Speed | 0.5° ~ 90°/s | | | |
| Presets | 256 | | | |
| Preset Accuracy | 0.225° | | | |
| Preset Speed | 5° ~ 400°/s | | | |
| Sequence | 8 | | | |
| Auto Pan | 4 | | | |
| Cruise | 8 | | | |
| Privacy Mask | 16 | | | |
| Proportional Pan & Tilt | On / Off (Pan and tilt speed proportional to zoom ratio) | | | |

| Items | S1 Model | S2 Model |
|-----------------------------|---|----------|
| Resume after Power loss | Yes | |
| Zone Title | 16 | |
| Home Function | Preset, Sequence, Auto pan, Cruise | |
| Auto Flip | Mechanical / Digital / Off | |
| Digital Slow Shutter | On / Off | |
| Electronic Image Stabilizer | - | |
| Day/Night: IR Cut Filter | On / Off | |
| Image Freeze | On / Off | |
| Image Inverse | On / Off | |
| Noise Reduction | 2D | On / Off |
| | 3D | On / Off |
| Alarm Input | 8 | |
| Alarm Output | 1 | |
| Alarm Reaction | Preset, Sequence, Auto pan, Cruise | |
| GENERAL | | |
| Environment | Indoor / Outdoor | |
| Controller Interface | RS-485 | |
| Operating Temperature | -45°C ~ 50°C (-49°F ~ 122°F) | |
| Waterproof Standard | IP66 standard | |
| Dimension | ∅172 x 302.5 mm (6.7 x 11.9 Inches) / ∅190 x 302.5 mm (7.5x 11.9 Inches), with sunshield | |
| Weight | 2.6 kg (5.7 lbs) | |
| Power Source | AC 24V ± 10% | |
| Power Consumption | 65 W (with Heater) | |
| Regulatory | CE, FCC, RoHS | |

**All Specifications are subject to change without notice.

OSD Menu Notes

The following OSD menu tables are provided for users to record various camera settings.

<G/V/T Model>

| Item | Layer 1 | Layer 2 | Layer 3 | Notes | |
|------------------------|--|---|--|-------|--|
| LANGUAGE | <ENGLISH>, <JAPANESE>, <PORTUGUESE>, <SPANISH>, <FRENCH>, <GERMAN>, <ITALIAN>, <POLISH>, <RUSSIAN>, <TRADITIONAL CHINESE>, <SIMPLIFIED CHINESE>, <TURKISH> | | | | |
| DEFAULT CAMERA | <ON>, <OFF> | | | | |
| BACKLIGHT | <ON>, <OFF> | | | | |
| FOCUS | AUTO | AF MODE <NORMAL>, <INTERVAL>, <ZOOM TRIG> EXIT + SAVE: YES | | | |
| | MANUAL | FOCUS SPEED <01>~<08> EXIT + SAVE: YES | | | |
| AE MODE | EXPOSURE COMP. | <OFF>, EXPOSURE VALUE: <-10.5dB> ~ <10.5dB> EXIT + SAVE: YES | | | |
| | AE MODE | AUTO | EXIT + SAVE: YES | | |
| | | BRIGHT | BRIGHT VALUE <00> ~ <31> EXIT + SAVE | | |
| | | SHUTTER | SHUTTER SPEED <1/10000>~<1> SEC. EXIT + SAVE: YES | | |
| | | IRIS | IRIS VALUE <CLOSE>, <F1.6> ~ <F28> EXIT + SAVE: YES | | |
| | MANUAL | BRIGHT VALUE: AUTO | | | |
| | | SHUTTER SPEED <1/10000> ~ <1> | | | |
| | | IRIS VALUE <F1.6> ~ <F28> GAIN VALUE <-3>dB ~ <28>dB EXIT + SAVE: YES | | | |
| | EXIT + SAVE | YES | | | |
| | WBC MODE | AUTO (Auto White Balance) | | | |
| INDOOR | | | | | |
| OUTDOOR | | | | | |
| ATW (Auto-tracing WBC) | | | | | |
| MANUAL | | R GAIN <000> ~ <127> B GAIN <000> ~ <127> EXIT + SAVE: YES | | | |
| SETUP MENU 1 | ZOOM SPEED | <1> ~ <8> | | | |
| | DIGITAL ZOOM | <ON>, <OFF> | | | |
| | SLOW SHUTTER | <ON>, <OFF> | | | |
| | IMAGE INVERSE | <ON>, <OFF> | | | |
| | FREEZE | <ON>, <OFF> | | | |
| | APERTURE | <01> ~ <16> | | | |
| | EXIT | YES | | | |
| SETUP MENU 2 | FLIP | <OFF>, <M.E.>, <IMAGE> | | | |
| | ANGLE ADJUSTER | MIN ANGLE <-10 ~ +10 DEG> MAX ANGLE <080 ~ 100 DEG> | | | |
| | SPEED BY ZOOM | <ON>, <OFF> | | | |
| | AUTO CALI. | <ON>, <OFF> | | | |
| | SYSTEM RESET | YES | | | |
| | EXIT | YES | | | |
| ID DISPLAY | <ON>, <OFF> | | | | |

| Item | Layer 1 | Layer 2 | Layer 3 | Notes |
|----------------------|------------------------------|---|---------|-------|
| TITLE DISPLAY | <ON>, <OFF> | | | |
| TITLE SETTING | <01> ~ <16> | | | |
| PRESET | PRESET SET | <001>~<256> | | |
| | PRESET RUN | <001>~<256> | | |
| | EXIT | YES | | |
| SEQUENCE | SEQUENCE LINE | <1> ~ <8> | | |
| | SEQUENCE POINT | <01> ~ <64> | | |
| | PRESET POS. | <001> ~ <255>, <END> | | |
| | SPEED | <01> ~ <15> | | |
| | DWELL TIME | <000> ~ <127> SEC. | | |
| | RUN SEQUENCE | ENTER | | |
| | EXIT | YES | | |
| AUTOPAN | AUTOPAN LINE | <1> ~ <4> | | |
| | START POINT | <TO FIND>, <TO SAVE> | | |
| | END POINT | <TO FIND>, <TO SAVE> | | |
| | DIRECTION | <RIGHT>, <LEFT> | | |
| | SPEED | <01> ~ <04> | | |
| | RUN AUTOPAN | ENTER | | |
| | EXIT | YES | | |
| CRUISE | CRUISE LINE | <1> ~ <8> | | |
| | RECORD START | ENTER | | |
| | RECORD END | ENTER | | |
| | RUN CRUISE | ENTER | | |
| | EXIT | YES | | |
| HOME SETTING | HOME FUNCTION | <ON>, <OFF> | | |
| | SELECT MODE | <PRESET>, <SEQUENCE>, <AUTOPAN>, <CRUISE> | | |
| | PRESET POINT | <001> ~ <256> | | |
| | SEQUENCE LINE | <1> ~ <8> | | |
| | AUTOPAN LINE | <1> ~ <4> | | |
| | CRUISE LINE | <1> ~ <8> | | |
| | RETURN TIME | <1> ~ <128> MIN. | | |
| | GO | ENTER | | |
| EXIT | YES | | | |
| IR FUNCTION | <AUTO> | THRESHOLD <01> ~ <29> EXIT + SAVE: YES | | |
| | <MANUAL> | IR MANUAL: <ON>, <OFF> EXIT + SAVE: YES | | |
| | | | | |
| ALARM SETTING | ALARM PIN | <1> ~ <8> | | |
| | ALARM SWITCH | <ON>, <OFF> | | |
| | ALARM TYPE | <NO> (Normal Open), <NC> (Normal Close) | | |
| | ALARM ACTION | <PRESET>, <SEQUENCE>, <AUTOPAN>, <CRUISE> | | |
| | PRESET POINT | <001> ~ <256> | | |
| | SEQUENCE LINE | <1> ~ <8> | | |
| | AUTOPAN LINE | <1> ~ <4> | | |
| | CRUISE LINE | <1> ~ <8> | | |
| DWELL TIME | <001> ~ <127> Sec., <ALWAYS> | | | |
| EXIT | YES | | | |
| ALARM DETECT | DETECT SWITCH | <ON>, <OFF> | | |
| | DETECT MODE | ON: <INT FOCUS>, <FIX FOCUS>, <FIX AE>, <MOTION>; OFF: NONE | | |
| | BLOCK MODE | NONE; MOTION: <ON>, <OFF> | | |
| | FRAME SET | NONE; MOTION: <01> ~ <04> | | |
| | FRAME DISABLE | NONE; MOTION: <01> ~ <04> | | |
| | THRESHOLD | NONE; MOTION: <001> ~ <255> | | |
| | EXIT | YES | | |
| WDR FUNCTION | <ON>, <OFF> | | | |
| PRIVACY MASK | PRIVACY | <ON>, <OFF> | | |

| Item | Layer 1 | Layer 2 | Layer 3 | Notes | |
|---------------------|--------------|---|------------------------------------|----------------------------|--|
| | SWITCH | | | | |
| | TRANSPARENCY | <ON>, <OFF> | | | |
| | COLOR | <BLACK>, <HI GRAY>, <LO GRAY>, <WHITE>, <RED>, <GREEN>, <BLUE>, <CYAN>, <YELLOW>, <MAGENTA> | | | |
| | SET MASK | <01> ~ <24> | H CENTER: L/R | | |
| | | | V CENTER: D/U | | |
| | | | H SIZE <000> ~ <080> | | |
| | | | V SIZE <000> ~ <060> | | |
| CLEAR MASK | <01> ~ <24> | | | | |
| EXIT | YES | | | | |
| TIME SETTING | TIME DISPLAY | <ON>, <OFF> | | | |
| | SET YEAR | <00> ~ <99> | | | |
| | SET MONTH | <01> ~ <12> | | | |
| | SET DAY | <00> ~ <31> | | | |
| | SET HOUR | <00> ~ <23> | | | |
| | SET MINUTE | <00> ~ <59> | | | |
| | EXIT+SAVE | | | | |
| SCHEDULE | SWITCH | <ON>, <OFF> | | | |
| | POINT | <01> ~ <32> | | | |
| | HOUR | <00> ~ <23> | | | |
| | MINUTE | <00> ~ <59> | | | |
| | MODE | NONE | | NO FUNCTION | |
| | | PRESET | | PRESET POINT <001> ~ <256> | |
| | | SEQUENCE | | SEQUENCE LINE <1> ~ <8> | |
| | | AUTOPAN | | AUTOPAN LINE <1> ~ <4> | |
| | | CRUISE | | CRUISE LINE <1> ~ <8> | |
| | IR FUNC. | | IR FUNCTION <AUTO>, <ON>, <OFF> | | |
| SCHEDULE RESET | YES | | | | |
| EXIT | YES | | | | |
| EXIT OSD | YES | | | | |

<L/M/R Model>

| Item | Layer 1 | Layer 2 | Layer 3 | Notes | |
|-----------------------|--|---|---|-------|--|
| LANGUAGE | <ENGLISH>, <JAPANESE>, <PORTUGUESE>, <SPANISH>, <FRENCH>, <GERMAN>, <ITALIAN>, <POLISH>, <RUSSIAN>, <TRADITIONAL CHINESE>, <SIMPLIFIED CHINESE>, <TURKISH> | | | | |
| DEFAULT CAMERA | <ON>, <OFF> | | | | |
| BACKLIGHT | <ON> | BLC LEVEL <00> ~ <30> EXIT + SAVE: YES | | | |
| | <OFF> | | | | |
| FOCUS | AUTO | TUNING VALUE <1.5M> (L Model only), <1M>, <30CM>, <10CM>, <1CM> EXIT + SAVE: YES | | | |
| | MANUAL | FOCUS SPEED <0> ~ <3> EXIT + SAVE: YES | | | |
| AE MODE | AUTO | IRIS OFFSET <00> ~ <15> EXIT + SAVE: YES | | | |
| | SHUTTER | SHUTTER SPEED R Model: <1/30000> ~ <1/60> (NTSC); <1/30000> ~ <1/50> (PAL) L/M Model: <1/30000> ~ <1/2> (NTSC); <1/30000> ~ <1/1.5> (PAL) EXIT + SAVE: YES | | | |
| | IRIS | <00> ~ <09> EXIT + SAVE: YES | | | |
| | AGC | <00> ~ <05> EXIT + SAVE: YES | | | |
| | WBC MODE | AUTO (Auto White Balance) | | | |
| WBC MODE | MANUAL | R GAIN <00> ~ <99> B GAIN <00> ~ <99> EXIT + SAVE: YES | | | |
| | | | | | |
| SETUP MENU 1 | ZOOM SPEED | <FAST>, <SLOW> | | | |
| | DIGITAL ZOOM | <OFF>, <02> ~ <12> | | | |
| | SLOW SHUTTER (L/M Model) | <1/2> ~ <1/60> (NTSC) <1/1.5> ~ <1/50> (PAL) | | | |
| | IMAGE INVERSE (L/M Model) | <ON>, <OFF> | | | |
| | FREEZE (L/M Model) | <ON>, <OFF> | | | |
| | APERTURE | <AUTO> | <MANUAL> H APERTURE <00> ~ <31> V APERTURE <00> ~ <31> | | |
| | STABILIZER (L Model Only) | <OFF>, <10Hz>, <5Hz> | | | |
| | EXIT | YES | | | |
| SETUP MENU 2 | FLIP | <OFF>, <M.E.>, <IMAGE>(L/M Model) | | | |
| | ANGLE ADJUSTER | MIN ANGLE <-10 ~ +10 DEG> MAX ANGLE <080 ~ 100 DEG> | | | |
| | SPEED BY ZOOM | <ON>, <OFF> | | | |
| | AUTO CALI. | <ON>, <OFF> | | | |
| | SYSTEM RESET | YES | | | |
| | EXIT | YES | | | |
| ID DISPLAY | <ON>, <OFF> | | | | |
| TITLE DISPLAY | <ON>, <OFF> | | | | |
| TITLE SETTING | <01> ~ <16> | | | | |
| PRESET | PRESET SET | <001> ~ <256> | | | |
| | PRESET RUN | <001> ~ <256> | | | |
| | EXIT | YES | | | |
| SEQUENCE | SEQUENCE LINE | <1> ~ <8> | | | |
| | SEQUENCE POINT | <01> ~ <64> | | | |

| Item | Layer 1 | Layer 2 | Layer 3 | Notes | |
|---|---------------------|---|------------------------|-------|--|
| | PRESET POS. | <001> ~ <255>, <END> | | | |
| | SPEED | <01> ~ <15> | | | |
| | DWELL TIME | <000> ~ <127> SEC. | | | |
| | RUN SEQUENCE | ENTER | | | |
| | EXIT | YES | | | |
| AUTOPAN | AUTOPAN LINE | <1> ~ <4> | | | |
| | START POINT | <TO FIND>, <TO SAVE> | | | |
| | END POINT | <TO FIND>, <TO SAVE> | | | |
| | DIRECTION | <RIGHT>, <LEFT> | | | |
| | SPEED | <01> ~ <04> | | | |
| | RUN AUTOPAN | ENTER | | | |
| | EXIT | YES | | | |
| CRUISE | CRUISE LINE | <1> ~ <8> | | | |
| | RECORD START | ENTER | | | |
| | RECORD END | ENTER | | | |
| | RUN CRUISE | ENTER | | | |
| | EXIT | YES | | | |
| HOME SETTING | HOME FUNCTION | <ON>, <OFF> | | | |
| | SELECT MODE | <PRESET>, <SEQUENCE>, <AUTOPAN>, <CRUISE> | | | |
| | PRESET POINT | <001> ~ <256> | | | |
| | SEQUENCE LINE | <1> ~ <8> | | | |
| | AUTOPAN LINE | <1> ~ <4> | | | |
| | CRUISE LINE | <1> ~ <8> | | | |
| | RETURN TIME | <1> ~ <128> MIN. | | | |
| | GO | ENTER | | | |
| EXIT | YES | | | | |
| IR FUNCTION (L/M Model) | <AUTO>, <ON>, <OFF> | THREADHOLD <MID>, <HI>, <LOW> | | | |
| | | IR COLOR <B/W>, <COLOR> | | | |
| | | EXIT + SAVE: YES | | | |
| ALARM SETTING | ALARM PIN | <1> ~ <8> | | | |
| | ALARM SWITCH | <ON>, <OFF> | | | |
| | ALARM TYPE | <NO> (Normal Open), <NC> (Normal Close) | | | |
| | ALARM ACTION | <PRESET>, <SEQUENCE>, <AUTOPAN>, <CRUISE> | | | |
| | PRESET POINT | <001> ~ <256> | | | |
| | SEQUENCE LINE | <1> ~ <8> | | | |
| | AUTOPAN LINE | <1> ~ <4> | | | |
| | CRUISE LINE | <1> ~ <8> | | | |
| | DWELL TIME | <001> ~ <127> Sec., <ALWAYS> | | | |
| EXIT | YES | | | | |
| ALARM DETECT (L/M Model only) | <ON>, <OFF> | | | | |
| WDR FUNCTION (L/M Model only) | <ON> | RATIO LEVEL <000> ~ <128> SHUTTER SPEED <000> ~ <128> IRIS OFFSET <000> ~ <128> EXIT <YES> | | | |
| | <AUTO> | | | | |
| | <OFF> | | | | |
| PRIVACY MASK (L/M Model only) | PRIVACY SWITCH | <ON>, <OFF> | | | |
| | MASK SHADE | <GRAY>, <WHITE>, <BLACK> | | | |
| | SET MASK | <01> ~ <08> | H CENTER <000> ~ <255> | | |
| | | | V CENTER <000> ~ <255> | | |
| | | | H SIZE <000> ~ <127> | | |
| | | | V SIZE <000> ~ <127> | | |
| | CLEAR MASK | <01> ~ <08>, <RESET> | | | |
| MASK DISPLAY | <FIRST>, <LAST> | | | | |
| EXIT | YES | | | | |

| Item | Layer 1 | Layer 2 | Layer 3 | Notes | |
|---------------------|----------------|-------------|------------------------------------|-------|--|
| TIME SETTING | TIME DISPLAY | <ON>, <OFF> | | | |
| | SET YEAR | <00> ~ <99> | | | |
| | SET MONTH | <01> ~ <12> | | | |
| | SET DAY | <00> ~ <31> | | | |
| | SET HOUR | <00> ~ <23> | | | |
| | SET MINUTE | <00> ~ <59> | | | |
| | EXIT+SAVE | | | | |
| SCHEDULE | SWITCH | <ON>, <OFF> | | | |
| | POINT | <01> ~ <32> | | | |
| | HOUR | <00> ~ <23> | | | |
| | MINUTE | <00> ~ <59> | | | |
| | MODE | NONE | NO FUNCTION | | |
| | | PRESET | PRESET POINT <001> ~ <256> | | |
| | | SEQUENCE | SEQUENCE LINE <1> ~ <8> | | |
| | | AUTOPAN | AUTOPAN LINE <1> ~ <4> | | |
| | | CRUISE | CRUISE LINE <1> ~ <8> | | |
| | | IR FUNC. | IR FUNCTION <AUTO>, <ON>, <OFF> | | |
| | SCHEDULE RESET | YES | | | |
| EXIT | YES | | | | |
| EXIT OSD | YES | | | | |

<S1/S2 Model>

| Item | Layer 1 | Layer 2 | Layer 3 | Notes | |
|-----------------------|--|--|---|--|--|
| LANGUAGE | <ENGLISH>, <JAPANESE>, <PORTUGUESE>, <SPANISH>, <FRENCH>, <GERMAN>, <ITALIAN>, <POLISH>, <RUSSIAN>, <TRADITIONAL CHINESE>, <SIMPLIFIED CHINESE>, <TURKISH> | | | | |
| DEFAULT CAMERA | <ON>, <OFF> | | | | |
| BACKLIGHT | <ON>, <OFF> | | BLC LEVEL <00> ~ <30> EXIT + SAVE: YES | | |
| | <OFF> | | | | |
| FOCUS | AUTO | | AF MODE <NORMAL>, <Z. TRIG.>, <PT TRIG.> EXIT+SAVE | | |
| | MANUAL | | | | |
| AE MODE | EXPOSURE COMP. | | <OFF>, EXPOSURE VALUE: <-10.5dB> ~ <10.5dB> EXIT + SAVE: YES | | |
| | AE MODE | AUTO | BRIGHT VALUE; SHUTTER SPEED; IRIS VALUE; GAIN VALUE: AUTO EXIT + SAVE: YES | | |
| | | | SHUTTER | SHUTTER SPEED PAL: <1/50> ~ <1/10000> SEC. NTSC: <1/60> ~ <1/10000> SEC. EXIT + SAVE: YES | |
| | | IRIS | IRIS VALUE <F1.6> EXIT + SAVE: YES | | |
| | | MANUAL | BRIGHT VALUE: AUTO SHUTTER SPEED PAL: <1/50> ~ <1/10000> SEC. NTSC: <1/60> ~ <1/10000> SEC. IRIS VALUE <F1.6> GAIN VALUE <-3>dB ~ <28>dB EXIT + SAVE: YES | | |
| | | | EXIT+ SAVE | YES | |
| | | | AUTO (Auto White Balance) | | |
| | | | INDOOR | | |
| | | OUTDOOR | | | |
| | WBC MODE | MANUAL | R GAIN <000> ~ <127> B GAIN <000> ~ <127> EXIT + SAVE: YES | | |
| | | | | | |
| SETUP MENU 1 | ZOOM SPEED | | <8> | | |
| | DIGITAL ZOOM | | <OFF>, <2x> ~ <12x> | | |
| | SLOW SHUTTER | | <ON>, <OFF> | | |
| | D.N.R. | 2D N.R. <ON>, <OFF> 3D N.R. <ON>, <OFF> EXIT + SAVE: YES | | | |
| | | | | | |
| | IMAGE INVERSE | | <ON>, <OFF> | | |
| | FREEZE | | <ON>, <OFF> | | |
| | APERTURE | | <01> ~ <16> | | |
| | EXIT | | YES | | |
| SETUP MENU 2 | FLIP | | <OFF>, <M.E.>, <IMAGE> | | |
| | ANGLE ADJUSTER | MIN ANGLE <-10 ~ +10 DEG> MAX ANGLE <080 ~ 100 DEG> EXIT + SAVE: YES | | | |
| | | | | | |
| | SPEED BY ZOOM | | <ON>, <OFF> | | |
| | AUTO CALI. | | <ON>, <OFF> | | |
| | PASSWORD | | <ON>, <OFF> | | |
| | OSD AUTO CLOSE | | <OFF>, <5> ~ <30> SEC. | | |
| | SYSTEM RESET | | SYSTEM RESET <YES> | | |

| Item | Layer 1 | Layer 2 | Layer 3 | Notes |
|----------------------|------------------------------|---|---------|-------|
| | | DEFAULT SYSTEM <YES> | | |
| | | EXIT <YES> | | |
| | EXIT | YES | | |
| ID DISPLAY | <ON>, <OFF> | | | |
| TITLE DISPLAY | <ON>, <OFF> | | | |
| TITLE SETTING | <01> ~ <16> | | | |
| PRESET | PRESET SET | <001>~<256> | | |
| | PRESET RUN | <001>~<256> | | |
| | EXIT | YES | | |
| SEQUENCE | SEQUENCE LINE | <1> ~ <8> | | |
| | SEQUENCE POINT | <01> ~ <64> | | |
| | PRESET POS. | <001> ~ <255>, <END> | | |
| | SPEED | <01> ~ <15> | | |
| | DWELL TIME | <000> ~ <127> SEC. | | |
| | RUN SEQUENCE | ENTER | | |
| | EXIT | YES | | |
| AUTOPAN | AUTOPAN LINE | <1> ~ <4> | | |
| | START POINT | <TO FIND>, <TO SAVE> | | |
| | END POINT | <TO FIND>, <TO SAVE> | | |
| | DIRECTION | <RIGHT>, <LEFT> | | |
| | SPEED | <01> ~ <04> | | |
| | RUN AUTOPAN | ENTER | | |
| | EXIT | YES | | |
| CRUISE | CRUISE LINE | <1> ~ <8> | | |
| | RECORD START | ENTER | | |
| | RECORD END | ENTER | | |
| | RUN CRUISE | ENTER | | |
| | EXIT | YES | | |
| HOME SETTING | HOME FUNCTION | <ON>, <OFF> | | |
| | SELECT MODE | <PRESET>, <SEQUENCE>, <AUTOPAN>, <CRUISE> | | |
| | PRESET POINT | <001> ~ <256> | | |
| | SEQUENCE LINE | <1> ~ <8> | | |
| | AUTOPAN LINE | <1> ~ <4> | | |
| | CRUISE LINE | <1> ~ <8> | | |
| | RETURN TIME | <1> ~ <128> MIN. | | |
| | GO | ENTER | | |
| EXIT | YES | | | |
| IR FUNCTION | AUTO | THRESHOLD <MID>, <HI>, <LOW> | | |
| | | EXIT + SAVE: YES | | |
| | MANUAL | IR MANUAL: <ON>, <OFF> | | |
| | | EXIT + SAVE: YES | | |
| ALARM SETTING | ALARM PIN | <1> ~ <8> | | |
| | ALARM SWITCH | <ON>, <OFF> | | |
| | ALARM TYPE | <NO> (Normal Open), <NC> (Normal Close) | | |
| | ALARM ACTION | <PRESET>, <SEQUENCE>, <AUTOPAN>, <CRUISE> | | |
| | PRESET POINT | <001> ~ <256> | | |
| | SEQUENCE LINE | <1> ~ <8> | | |
| | AUTOPAN LINE | <1> ~ <4> | | |
| | CRUISE LINE | <1> ~ <8> | | |
| DWELL TIME | <001> ~ <127> Sec., <ALWAYS> | | | |
| EXIT | YES | | | |
| ALARM DETECT | <NONE> | | | |
| WDR FUNCTION | <NONE> | | | |
| PRIVACY MASK | PRIVACY SWITCH | <ON>, <OFF> | | |
| | TRANSPARENCY | <ON>, <OFF> | | |

| Item | Layer 1 | Layer 2 | Layer 3 | Notes | |
|---------------------|----------------|---|------------------------------------|-------|--|
| | COLOR | <BLACK>, <WHITE>, <RED>, <GREEN>, <BLUE>, <CYAN>, <YELLOW>, <MAGENTA> | | | |
| | SET MASK | <01> ~ <16> | H CENTER: L/R | | |
| | | | V CENTER: D/U | | |
| | | | H SIZE <000> ~ <080> | | |
| | | | V SIZE <000> ~ <060> | | |
| CLEAR MASK | <01> ~ <16> | | | | |
| EXIT | YES | | | | |
| TIME SETTING | TIME DISPLAY | <ON>, <OFF> | | | |
| | SET YEAR | <00> ~ <99> | | | |
| | SET MONTH | <01> ~ <12> | | | |
| | SET DAY | <00> ~ <31> | | | |
| | SET HOUR | <00> ~ <23> | | | |
| | SET MINUTE | <00> ~ <59> | | | |
| | EXIT+SAVE | | | | |
| SCHEDULE | SWITCH | <ON>, <OFF> | | | |
| | POINT | <01> ~ <32> | | | |
| | HOUR | <00> ~ <23> | | | |
| | MINUTE | <00> ~ <59> | | | |
| | MODE | NONE | NO FUNCTION | | |
| | | PRESET | PRESET POINT <001> ~ <256> | | |
| | | SEQUENCE | SEQUENCE LINE <1> ~ <8> | | |
| | | AUTOPAN | AUTOPAN LINE <1> ~ <4> | | |
| | | CRUISE | CRUISE LINE <1> ~ <8> | | |
| | | IR FUNC. | IR FUNCTION <AUTO>, <ON>, <OFF> | | |
| | SCHEDULE RESET | YES | | | |
| EXIT | YES | | | | |
| EXIT OSD | YES | | | | |